

TRUCK LEVELER

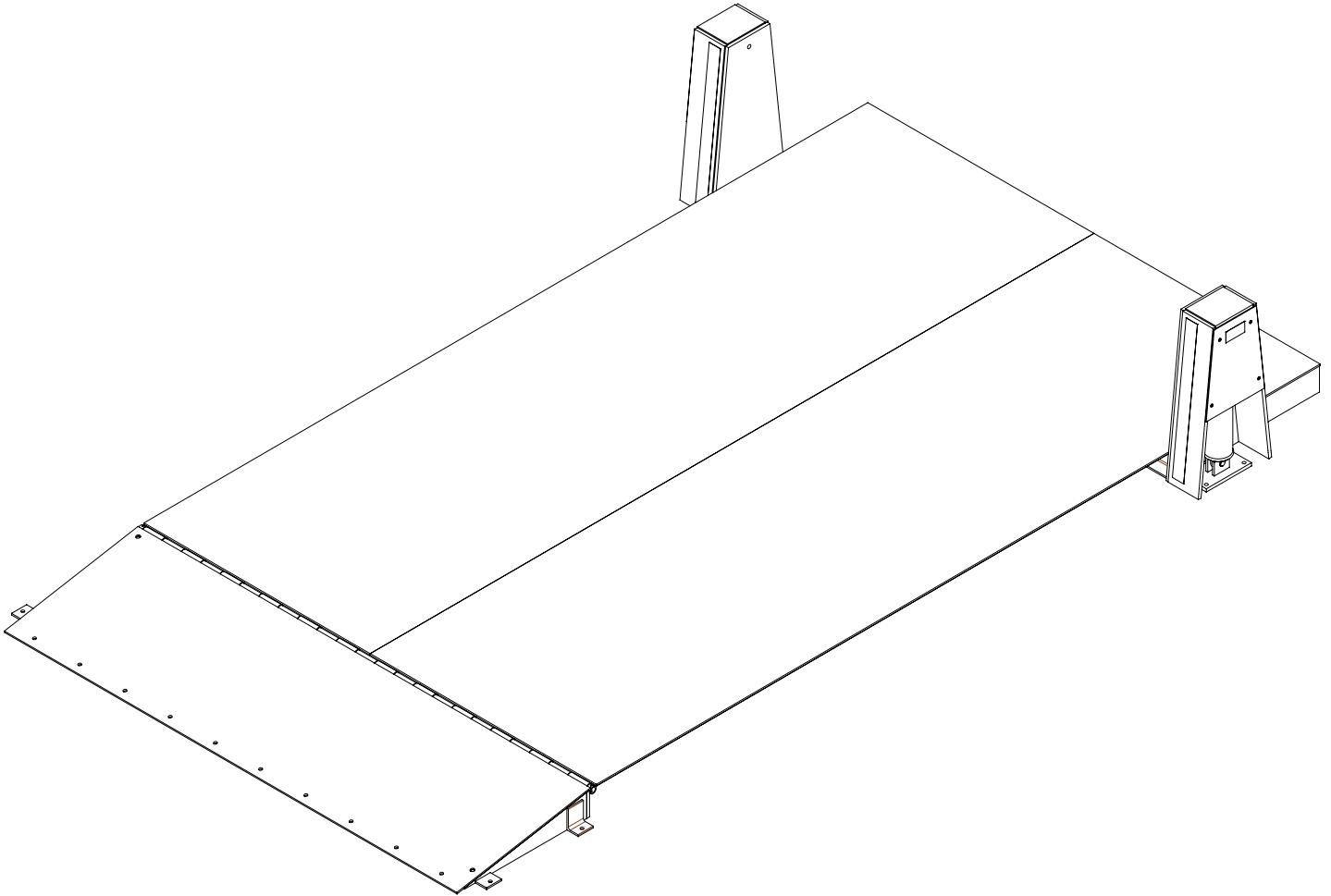

This manual applies to truck leveler units manufactured beginning May 2012 with serial number 61045510 and higher.

▲ WARNING

Do not install, operate or service this product unless you have read and understand the Safety Practices, Warnings, Installation and Operating Instructions contained in this User's Manual. Failure to do so could result in death or serious injury.

User's Manual Installation, Operations, Maintenance and Parts

Part No. 6010140D

TABLE OF CONTENTS

Introduction.....	2	Electrical Schematic	12
Safety Signal Words	2	Planned Maintenance.....	13
Safety Practices.....	3	Hydraulic Schematic.....	15
Installation	4	Parts List.....	16
Operating Instructions	8	Notes	20
Troubleshooting.....	9	Limited Warranty	23
Specifications	10	Distributor Information	24

INTRODUCTION

Welcome and thank you for choosing this truck leveler.

This User's Manual contains information that you need to safely install, operate and maintain the truck leveler. It also contains a complete parts list and information about ordering replacement parts. Please keep and read this User's Manual before using your new light system.

SAFETY SIGNAL WORDS

You may find safety signal words such as DANGER, WARNING, CAUTION or NOTICE throughout this Owner's Manual. Their use is explained below:



This is the safety alert symbol. It is used to alert you to potential personal injury hazards. Obey all safety messages that follow this symbol to avoid possible death or injury.

▲ DANGER

Indicates an imminently hazardous situation which, if not avoided, will result in death or serious injury.

▲ WARNING

Indicates a potentially hazardous situation which, if not avoided, could result in death or serious injury.

▲ CAUTION

Indicates a potentially hazardous situation which, if not avoided may result in minor or moderate injury.

NOTICE

Notice is used to address practices not related to personal injury.

SAFETY PRACTICES

⚠ WARNING

Read these safety practices before installing, operating or servicing the wheel restraint. Failure to follow these safety practices could result in death or serious injury.

If you do not understand the instructions, ask your supervisor to explain them to you or call your local distributor.

OPERATION

Use restricted to trained operators.

Use by untrained people can cause property damage, bodily injury and/or death. Your supervisor should teach you the safe and proper way to use the truck leveler. Read and follow the complete OPERATION PROCEDURE on page 8 before use. **DO NOT USE THE TRUCK LEVELER IF IT IS NOT WORKING RIGHT.** Tell your supervisor it needs repair.

Keep hands and feet clear of the truck leveler at all times. Stay clear of the truck leveler when it is moving.

BE CERTAIN TO RESTRAIN VEHICLE USING WHEEL CHOCKS OR OTHER SUITABLE VEHICLE RESTRAINT BEFORE ANY LOADING OR UNLOADING.

Before chocking wheels or engaging vehicle restraint, dump air from air ride suspensions and set parking brakes.

INSTALLATION, MAINTENANCE AND SERVICE

Before doing maintenance or service be certain that the power is disconnected and properly tagged or locked out. Failure to follow these safety practices may result in death or serious injury.

BE CERTAIN TO MANUALLY CHOCK THE VEHICLE WHEELS BEFORE LOADING OR UNLOADING.

Place barricades around pit on dock floor and drive while installing, maintaining or repairing truck leveler.

Do not stand in the driveway between the dock and a backing vehicle.

Do not use the truck leveler as a step.

Keep hands and feet clear of moving parts at all times.

All electrical troubleshooting and repair must be done by a qualified technician and meet all applicable codes.

Disconnect the power and properly tag or lock off before doing any electrical work.

If it is necessary to make troubleshooting checks inside the control box with the power on, **USE EXTREME CAUTION!** Do not place fingers or uninsulated tools inside the control box. Touching wires or other parts inside the control box could result in electrical shock, death or serious injury.

INSTALLATION

FOR UNITS SHIPPED IN 2 SECTIONS (SKIP TO PAGE 7 FOR UNITS SHIPPED IN 1 PIECE)

1. Fit the deck sections together. Insert the hinge angle between the deck hinges. Grease the hinge rod and feed through the aligned hinge tubes. See Fig. 1.
2. Insert roll pins through the end hinge tubes. Remove the four inner lifting lugs as shown. See Fig. 2.

Fig. 1

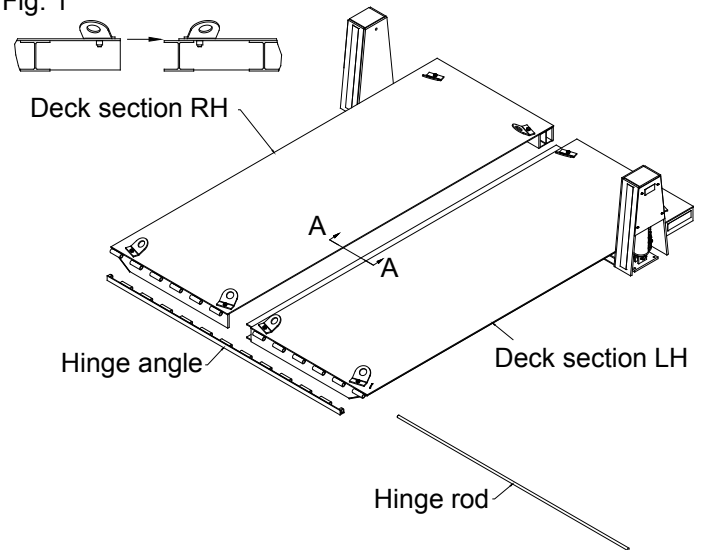
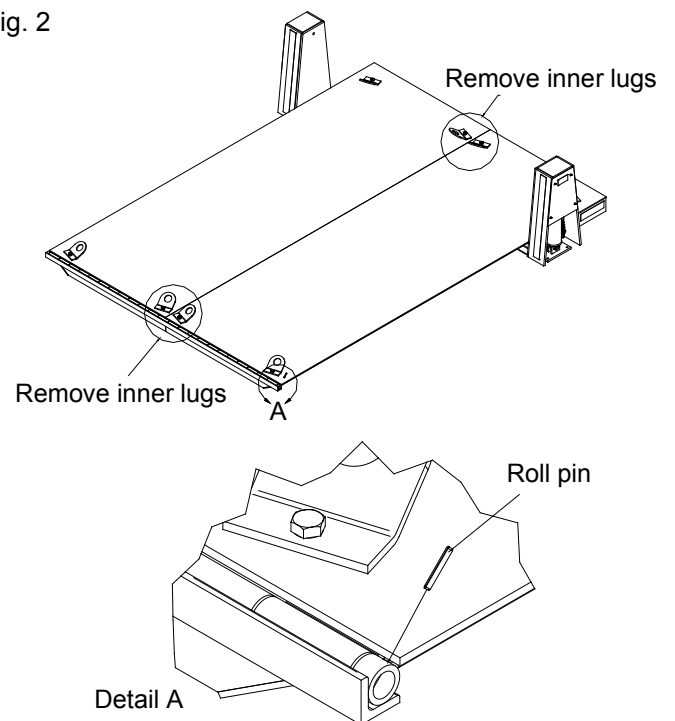

Fig. 2



INSTALLATION, continued

3. On the hinge end of the decks, ensure the deck plates are firmly in contact and level. Continuously weld the hinge end skirt together. (Uphill weld only on vertical welds. Do not use downhill welds.) Continuously weld the top of deck plates together 24" from the forward (hinge end) edge. Install deck strapping plate with 4" long bolts and washer. See Fig. 3.
4. On the cylinder end of the deck, ensure the deck plates are fit together, firmly in contact and level. Position the mating skirt against the deck skirt. Continuously weld the top and sides of the mating skirt to the deck skirt. (Uphill weld only on vertical welds. Do not use downhill welds.) Continuously weld the top of deck plates together 24" from the edge. Install deck strapping plate with 4" long bolts and washer. See Fig. 4.
5. Carefully turn the unit over. Ensure the deck plate is firmly in contact with the center beam. Weld the center beam to the deck plate, deck header and deck skirt as shown. See Fig. 5.

Fig. 3

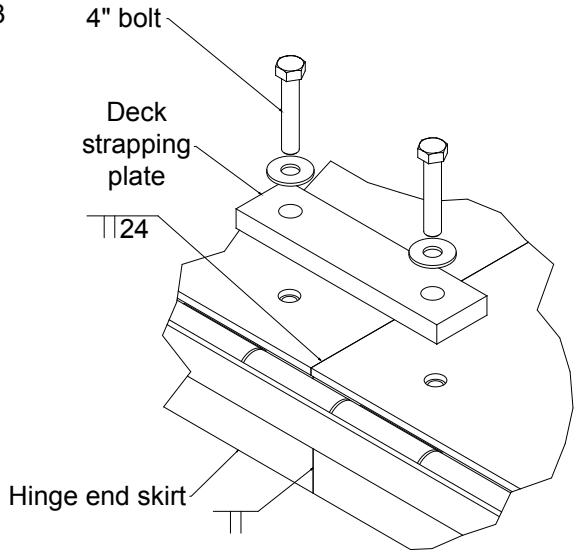

Fig. 4

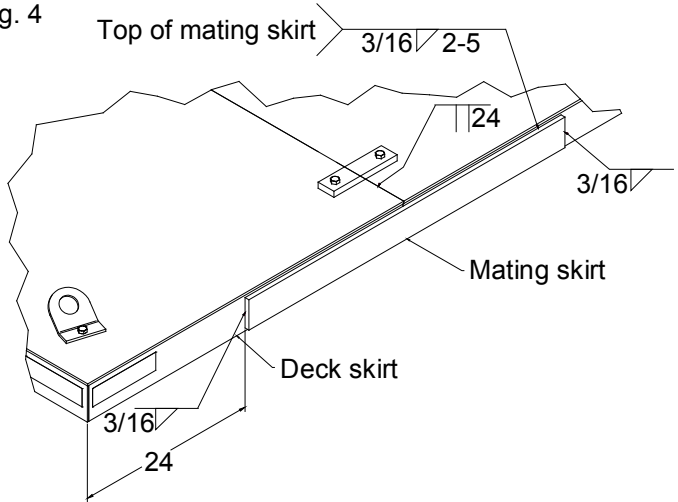
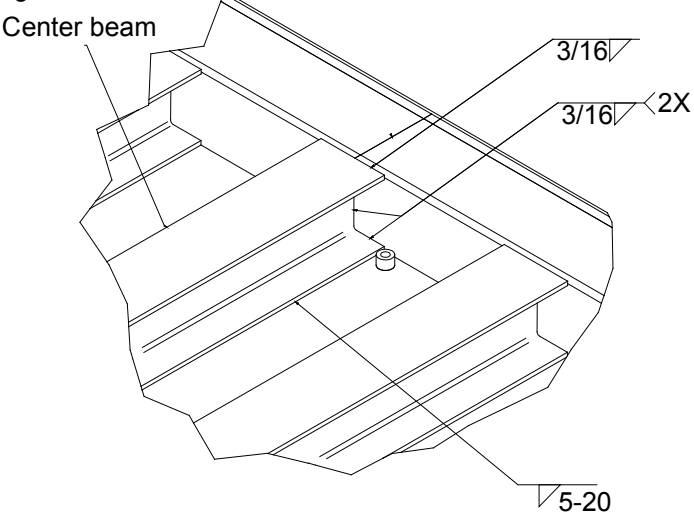

Fig. 5



INSTALLATION, continued

6. Position the mating skirt against the deck header. Weld the top and sides of the mating skirt to the deck header. Uphill welds only, do not use downhill welds. See Fig. 6.
7. Position the cylinder plate as shown. Continuously weld each side of the cylinder plate to each beam and each cylinder enclosure. See Fig. 6.
8. Position the reinforcement plate as shown. Continuously weld each side of the reinforcement plate to each beam. Touch up paint as required. See Fig. 7.
9. Carefully turn the unit over. Ensure the deck plates are firmly in contact and level. Weld the deck plates together. Touch up paint as required. Remove the deck strapping plates. See Fig. 8.

Fig. 6

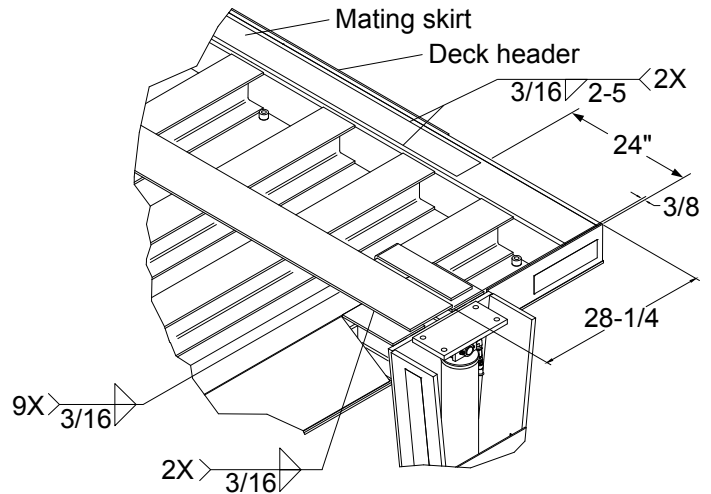

Fig. 7

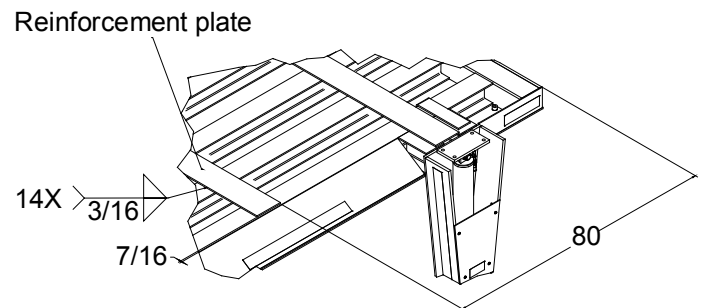
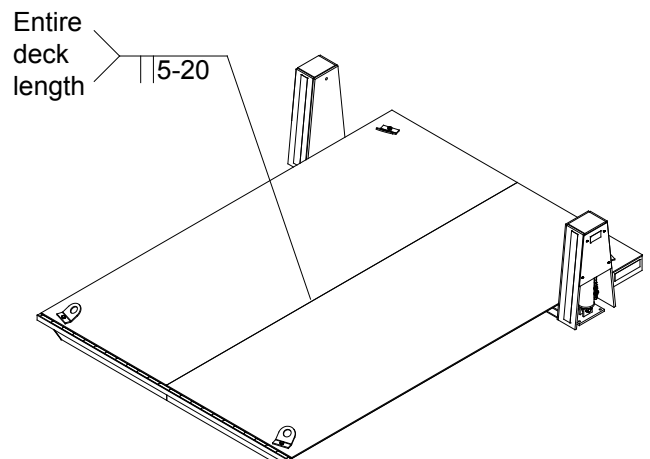

Fig. 8



PIT MOUNTED INSTALLATION

⚠ WARNING

Before installation read and follow all safety practices shown on page 3 and the operation section of the manual.

Improper installation of the truck leveler could result in death or serious injury to dock workers or other users of the truck leveler.

Place barricades around pit on dock floor and drive while installing, maintaining or repairing truck leveler.

Be certain bystanders in the driveway stand clear when truck leveler is operated.

1. Before installing truck leveler, use the certified pit drawings to check the entire pit for correct dimensions and conduit locations.
2. If your unit was shipped in one piece, grease hinge rod and feed through hinge tubes on deck and rear hinge angle. Insert roll pins through end hinge tubes.
2. Weld the four hinge angle support plates (supplied) to the 8" channel at front of pit. See Fig. 9.
3. Disconnect the #6 hose linking the two lift cylinders and feed through conduit running laterally across pit.

NOTICE

Whenever running any hoses through conduit, the end of the hose must be capped in order to prevent dirt and other debris from entering the hydraulic system.

4. Feed length of #8 hose (supplied) through conduit from power unit location to truck leveler pit.
5. Position power unit and anchor to floor.
6. Attach #8 hose to power unit.
7. Remove cylinder shipping bolts from both cylinder base brackets.
8. Place a chain or other suitable lifting device through the lugs located at the four corners of the deck. The lifting lugs have been provided for the purpose of lifting during installation. The truck leveler should not be lifted in any other manner when placing into position. See Fig. 10.

Fig. 9

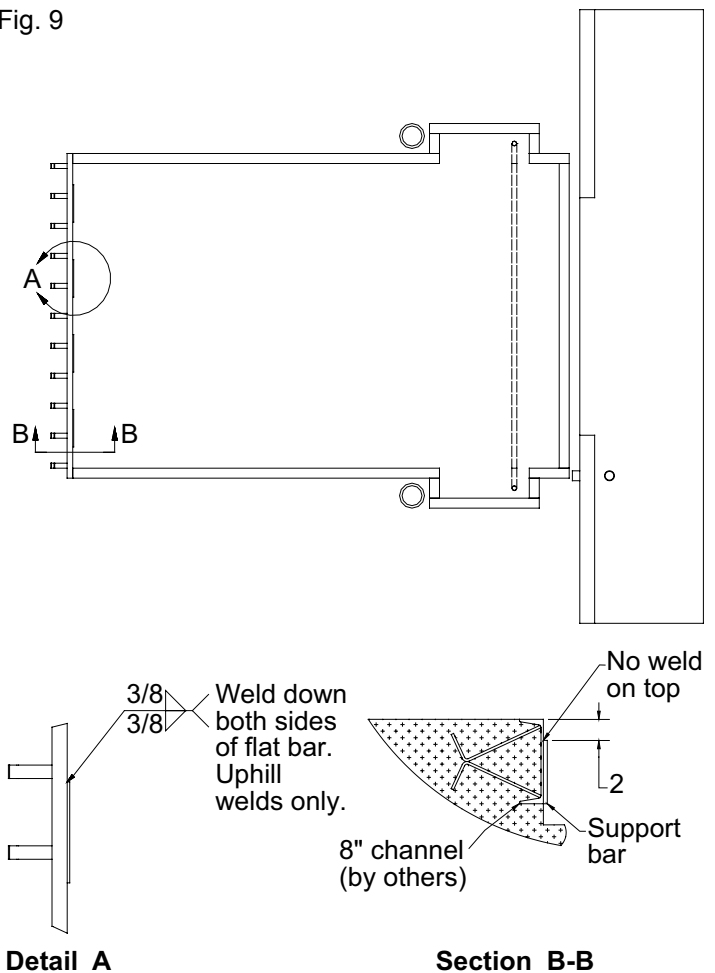
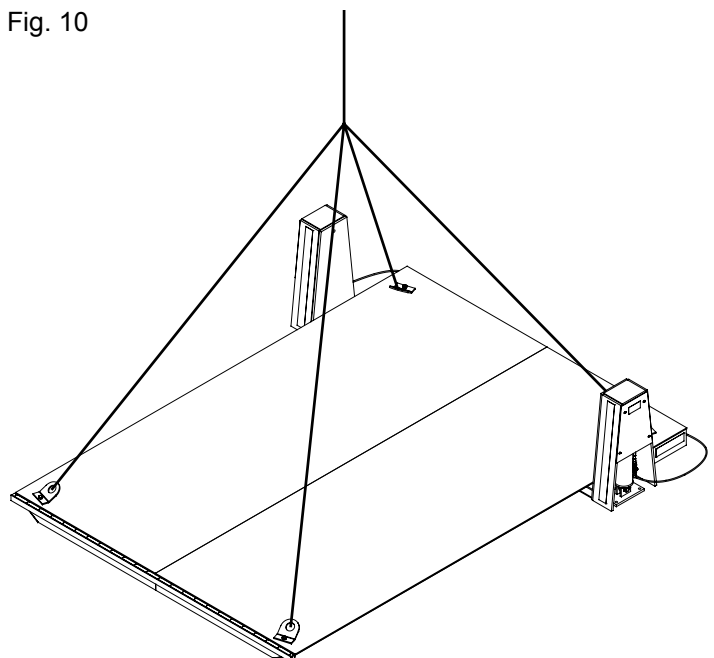

Fig. 10



INSTALLATION, continued

⚠ WARNING

Make sure lifting devices are in good condition and have a lifting capacity of at least 15,000 lb. at the lifting angle they are being used at. Stand clear of the truck leveler when it is being placed into position. Never allow anyone to stand on or near the truck leveler when it is being lifted or placed into position. The truck leveler can tip or swing into bystanders causing severe injury and/or death.

9. Lift the entire unit into the pit. Square deck with pit sides, shimming behind hinge angle where necessary. Hinge angle should rest on top of support plates welded in step 2. Weld behind each stationary hinge segment to 8" channel. See Fig. 11.
10. Manually extend each lifting cylinder until the base bracket contacts the pit floor. Ensure lifting cylinder is plumb when truck leveler is at level grade. Anchor cylinder base brackets in position with 5/8" x 4-1/2" wedge anchors.
11. Attach #8 lift hose to fitting at base of large lift cylinder. Attach #6 hose to lift cylinders. See Fig. 12.
12. Attach control panel to wall adjacent the dock opening on the left side facing out from inside the dock at approximately 5' from the ground to center of control panel. Check incoming power for correct voltage and run power to control panel through a fused disconnect supplied by others. Wire from control panel to power unit per wiring diagram on page 16. Apply power to control panel.
13. Perform lift cylinder synchronization procedure. See Fig. 12 and procedure on page 9.
14. Reverse the motor rotation (if necessary) as follows:
 - 14.1 Disconnect power.
 - 14.2 Reverse the motor wiring by switching any two of the three motor wires connected to the overload relay: T1, T2, and T3.
 - 14.3 Reapply power.
15. Anchor outside guardrails with 3/8" x 3" wedge anchors.

Fig. 11

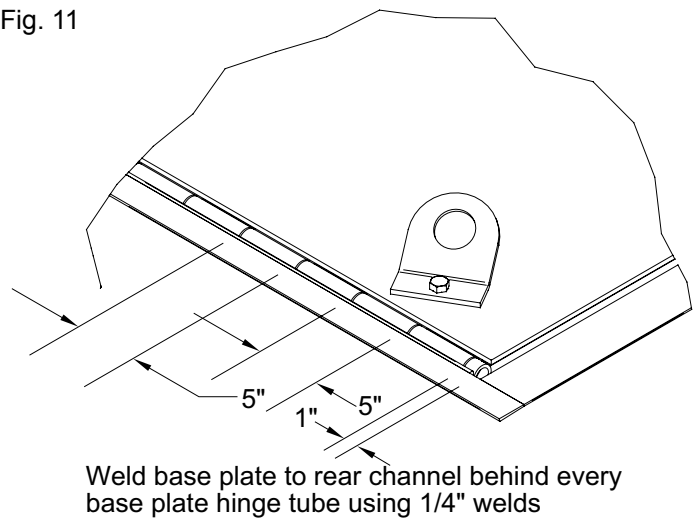
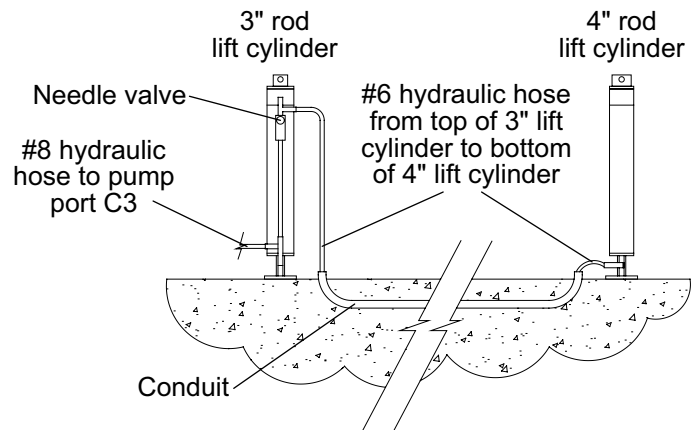

Fig. 12



LIFT CYLINDER SYNCHRONIZATION

The two main lifting cylinders are synchronized before they leave the factory. It should only be necessary to re-synchronize them if the #6 hose connecting them is disconnected allowing air to enter the line. This hose should only be disconnected if it is required to run it through conduit as in a pit mounted truck leveler installation.

PROCEDURE

1. Remove any load from the truck leveler
2. Remove the lift cylinder cover plates.
3. Open the needle valve on the larger cylinder (3" diameter rod) by first loosening the Allen key set screw and then turning the knurled knob counter-clockwise two turns.
4. Depress the RAISE button to raise the truck leveler to its highest position.
5. Purge any air from the smaller "slave" cylinder (4" diameter rod) by slowly loosening the bleeder screw at the top of the cylinder housing until only oil escapes. Tighten the bleeder screw.
6. Raise the truck leveler to its highest position. Close the needle valve by turning clockwise until tight and then tighten lock screws.
7. Replace the lift cylinder cover plates.

INSTALLATION, continued

SURFACE MOUNTED INSTALLATION

1. Position power unit and anchor to floor.
2. Place a chain or other suitable lifting device through the lugs located at the four corners of the deck. The lifting lugs have been provided for the purpose of lifting during installation. The truck leveler should not be lifted in any other manner when placing into position. See Fig. 10.

⚠ WARNING

Make sure lifting devices are in good condition and have a lifting capacity of at least 15,000 lb. at the lifting angle they are being used at. Stand clear of the truck leveler when it is being placed into position. Never allow anyone to stand on or near the truck leveler when it is being lifted or placed into position. The truck leveler can tip or swing into bystanders causing severe injury and/or death.

3. Set the unit in place, centered to the dock door and 4" out from the bumper face. See Fig. 13.
4. Block up the lift cylinder end of the deck to facilitate attachment of ramp assembly at other end of deck.
5. Grease hinge rod and feed through hinge tubes on deck and ramp. Insert roll pins through end hinge tubes.
6. Anchor ramp assembly in place with 5/8" x 4-1/2" spike anchors.
7. Place the #6 hose linking the two cylinders on ground between deck and building wall.
8. Attach #8 hose to power unit. Feed through conduit to master lift cylinder location on deck assembly.

Fig. 13

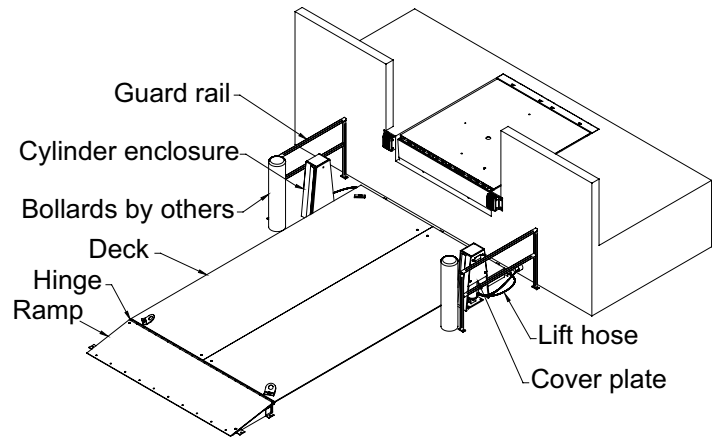

NOTICE

Dirt or debris in the hydraulic system can hamper proper operation of the truck leveler. Do not allow dirt or debris to enter the hoses.

9. Connect #8 hose to fitting at base of large lift cylinder.
10. Attach control panel to wall adjacent the dock opening on the left side facing out from inside the dock at approximately 5' from the ground to center of control panel. Check incoming power for correct voltage and run power to control panel through a fused disconnect supplied by others. Wire from control panel to power unit per wiring diagram on page 16. Apply power to control panel.
11. Extend the lifting cylinders by depressing the RAISE button (standard panel) until the base brackets contact the slab. Ensure lifting cylinders are plumb when truck leveler is level. Anchor cylinder base brackets in position with 5/8" x 4-1/2" wedge anchors.
12. Reverse the motor rotation (if necessary) as follows:
 - 12.1 Disconnect power.
 - 12.2 Reverse the motor wiring by switching any two of the three motor wires connected to the overload relay: T1, T2, and T3.
 - 12.3 Reapply power.
13. Position hose guard assembly over top of hydraulic hose between leveler and building. Anchor to slab with 5/8" x 4-1/2" wedge anchors.
14. Anchor outside guardrails with 3/8" x 3" wedge anchors such that access is denied between the cylinder and dock.

OPERATING INSTRUCTIONS

OPERATING INSTRUCTIONS (FOR STANDARD CONTROL PANELS)

▲ WARNING

Before operating Truck Leveler read and follow all safety practices listed on page 3.

Do not use the Truck Leveler if it looks broken or does not seem to work right.

Inform your supervisor immediately.

Stay clear of the Truck Leveler when it is moving.

Keep hands and feet clear at all times.

Do not operate the Truck Leveler with equipment, material, or people directly in its path.

Before raising vehicle, it MUST be properly restrained with a suitable vehicle restraint system.

Failure to follow these safety practices may result in serious injury or death

TO RAISE VEHICLE :

1. Before raising vehicle, it MUST be properly restrained with a suitable vehicle restraint system.
2. Once vehicle is safely chocked, it may be raised by pressing and holding the "RAISE" button until the vehicle bed is at the desired height.
3. Vehicle may now be loaded or unloaded

TO LOWER VEHICLE :

1. Press the lower pushbutton until the Truck Leveler is fully lowered
2. Remove vehicle restraint
3. Vehicle may now leave the loading area

TROUBLESHOOTING

▲ DANGER

Before doing any maintenance or service remove power at the fused disconnect during all electrical or mechanical service. Disconnect must be properly locked out during maintenance or service of equipment. Failure to disconnect power may result in serious injury or death.

▲ WARNING

Before doing any maintenance or repair read and follow the safety practices listed on page 3 and the operations section of this manual.

Place barricades on the dock floor around the truck leveler and in the driveway in front of the equipment while installing, maintaining or repairing the truck leveler.

NOTE:

This troubleshooting section assumes that the truck leveler has been installed properly and that all electrical and hydraulic connections have been made correctly. If this is a new installation or electrical or hydraulic work has been done on the unit, refer to the appropriate schematics and/or instructions to verify that the unit is installed correctly.

RAMP WILL NOT LIFT (when RAISE button is pressed)

1. MOTOR RUNS

- 1.1 Too much weight on ramp
- 1.2 Ramp already at maximum height
- 1.3 Pressure relief valve set too low - factory set at 2800 PSI
- 1.4 Leaking or broken hose connection
- 1.5 Failed pump or pump/motor coupling

2. MOTOR DOES NOT RUN

- 2.1 Overload has been tripped
- 2.2 Other electrical problem - consult appropriate schematic

3. RAMP WILL NOT LOWER

(when LOWER button is pressed)

- 3.1 Ramp is already in the fully lowered position
- 3.2 Defective lowering solenoid valve or coil. Replace
- 3.3 Obstruction underneath ramp preventing downward travel. Remove obstruction
- 3.4 Velocity fuse(s) in lift cylinders tripped. Reset velocity fuses by pressing raise button to lift ramp slightly
- 3.5 Other electrical problem - consult appropriate schematic

4. RAMP RAISES UNEVENLY

- 4.1 Lift cylinders not synchronized. Follow synchronizing procedure described on page 9.
- 4.2 Leak or break in #6 hose connecting the two lifting cylinders. Repair or replace

SPECIFICATIONS

GENERAL

PLATFORM SIZE

TL 1014: 120" wide x 168" long

TL 1016: 120" wide x 192" long

TL 1020: 120" wide x 238" long

LIFTING CAPACITY

60000 lb.

VERTICAL TRAVEL

24" Standard

36" Optional

PLATFORM WEIGHT

24" Travel:

TL 1014 surface mount: 7193 lbs

TL 1014 pit mount: 6484 lbs

TL 1016 surface mount: 8071 lbs

TL 1016 pit mount: 7362 lbs

TL 1020 surface mount: 9801 lbs

TL 1020 pit mount: 9092 lbs

36" Travel:

TL 1014 surface mount: 7319 lbs.

TL 1014 pit mount: 6610 Lbs.

TL 1016 surface mount: 8158 Lbs.

TL 1016 pit mount: 7488 Lbs.

TL 1020 surface mount: 9903 Lbs.

TL 1020 pit mount: 9233 Lbs.

POWER UNIT

PUMP

3.2 GPM @ 1725 RPM (gear pump)

MOTOR

5 HP, 3 PH, 1725 RPM, TEFC, continuous duty

Approx. full load amperage:

208V/3PH/14.6A

230V/3PH/13.2A

460V/3PH/6.6A

575V/3PH/5.2A

PRESSURE RELIEF SETTING

2800 PSI

FLOW CONTROL

Fixed- 7 GPM

RESERVOIR CAPACITY

10 gallon.

Acceptable Fluids: An all weather hydraulic fluid with a viscosity of 15 CSt at 40°C (100°F), such as:

Shell Tellus T 15

Mobil Aero HFA (49011)

Exxon Univis: HV13, N15, J13

Texaco Aircraft Oil #1554

U.S. Oil Co., Inc #ZFI-5606 (Low Temp.)

CONTROL PANEL

WIRING SCHEMATIC

See page 12

SECONDARY CONTROL VOLTAGE

24 VAC

CYLINDERS

Lift fully synchronized

24" TRAVEL (STANDARD)

1 - 5" Diameter piston, 3" diameter rod, 31-3/4" collapsed length, 21-5/8" stroke

1 - 4" Diameter ram, 31-3/4" collapsed length, 21-5/8" stroke

36" TRAVEL (OPTIONAL)

1 - 5" Diameter piston, 3" diameter rod, 40-1/4" collapsed length, 30-1/8" stroke

1 - 4" Diameter ram, 40-1/4" collapsed length, 30-1/8" stroke

ELECTRICAL SCHEMATIC

⚠ DANGER

Before doing any electrical work, make certain the power is disconnected and properly tagged or locked off. All electrical work must be done by a qualified technician and meet all applicable codes. If it is necessary to make troubleshooting checks inside the control box with the power on, USE EXTREME CAUTION. Do not place your fingers or uninsulated tools inside the control box. Touching wires or other parts inside the control box could result in electrical shock, death or serious injury.

Fig. 14 208-600V/3PH/50-60HZ

CB/FU TO BE SUPPLIED BY OTHERS
 SUPPLY BCPD = CB/FU (SEE TABLE)
 PANEL FLA (SEE TABLE)
 SCCR = 5KA

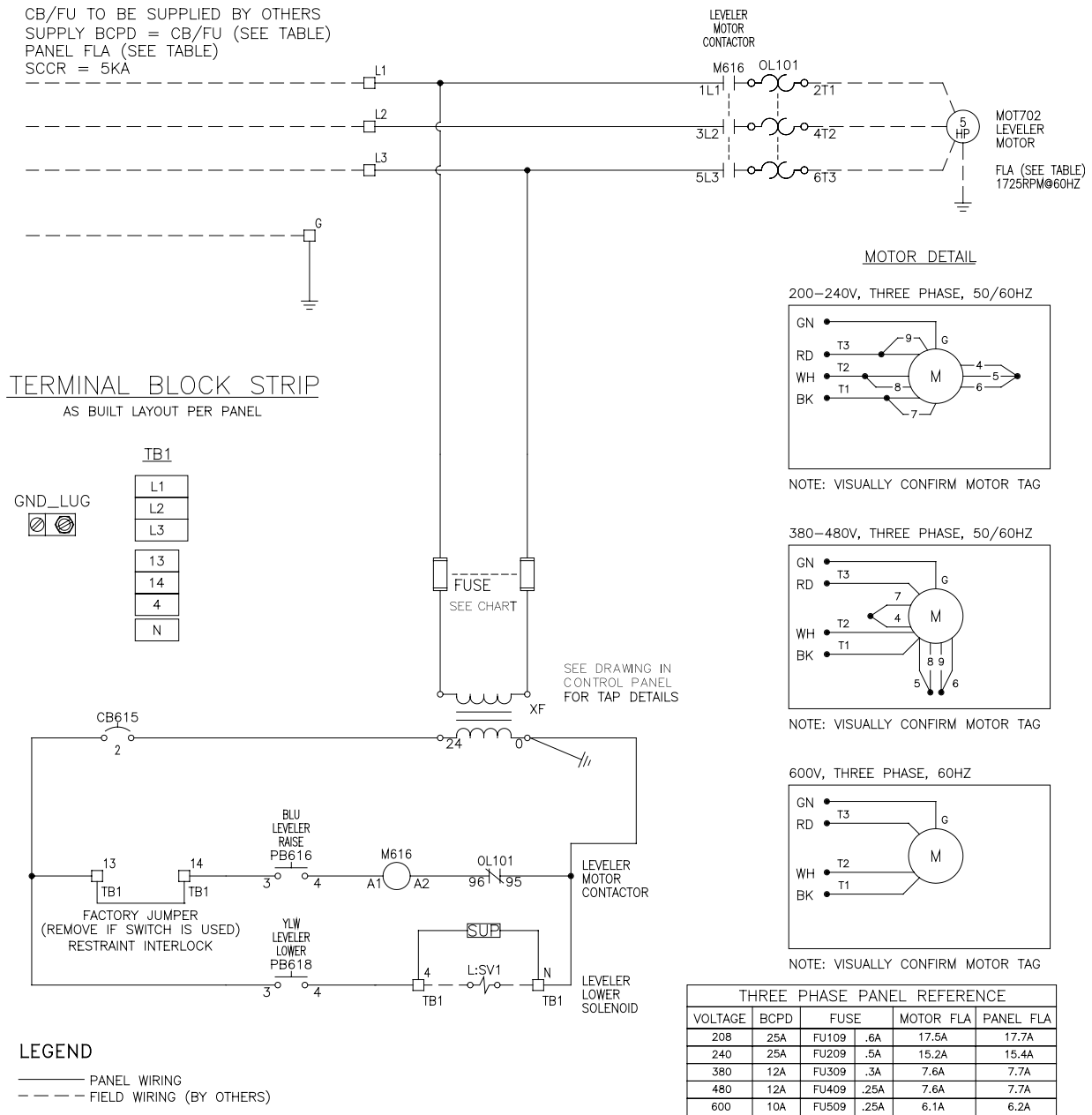

PLANNED MAINTENANCE

▲ DANGER

Be certain, before doing any maintenance or repair on the equipment, that the power is disconnected and properly tagged or locked off.

▲ WARNING

Before servicing the truck leveler, read and follow the Safety Practices on page 3 and the operation section of this manual.

Place barricades on the dock floor around the truck leveler and in the driveway in front of the equipment while installing, maintaining or repairing the truck leveler.

Hydraulic Fluid - An all weather hydraulic fluid with a viscosity of 15 CSt at 40°C (100°F), such as:

Shell Tellus T 15

Mobil Aero HFA (49011)

Exxon Univis: HV13, N15, J13

Texaco Aircraft Oil #1554

U.S. Oil Co., Inc #ZFI-5606 (Low Temp.)

WEEKLY

1. Check for leaks on the hydraulic power unit.
2. Check for damaged hydraulic fittings.
3. Check that pins and pin locks are in place.
4. Clean hydraulic cylinders, ramp hinge assembly, hydraulic hoses and truck leveler pit to remove debris.

MONTHLY

1. Check for damaged hinge tubes on ramp hinge assembly.
2. Check for cuts in hoses and loose or leaking fittings.
3. Adjust hydraulics to maintain level deck (if required).
4. Lubricate ramp hinge assembly.

QUARTERLY





1. Grease fitting on spherical bearing at bottom of lift cylinders.
2. Visually inspect labels and replace if worn or missing.
3. Check level and condition of hydraulic fluid.

ANNUALLY

1. Drain, flush and change oil. Use only oils specified.
2. Remove and clean hydraulic oil pump strainer and reservoir.

PLANNED MAINTENANCE

Fig. 15

Legend	
Symbol	Description
	Lubricate - Oil Light Oil - SAE 30
	Lubricate - Grease Molybdenum disulfide NLGI #2
	Cleaning (Location - frequency)
	Visually Inspect (Replace damaged or worn)

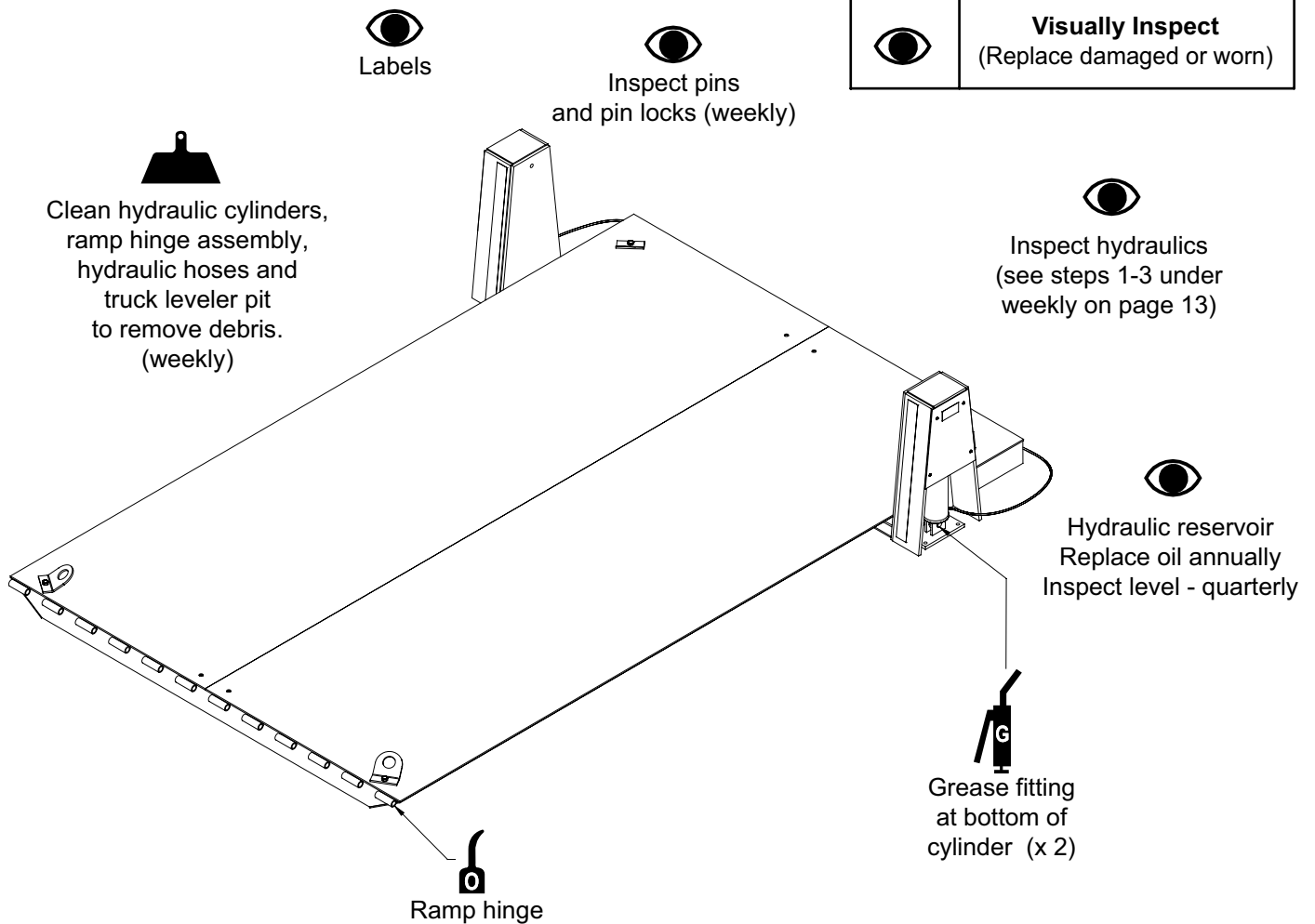

HYDRAULIC SCHEMATIC

Fig. 16

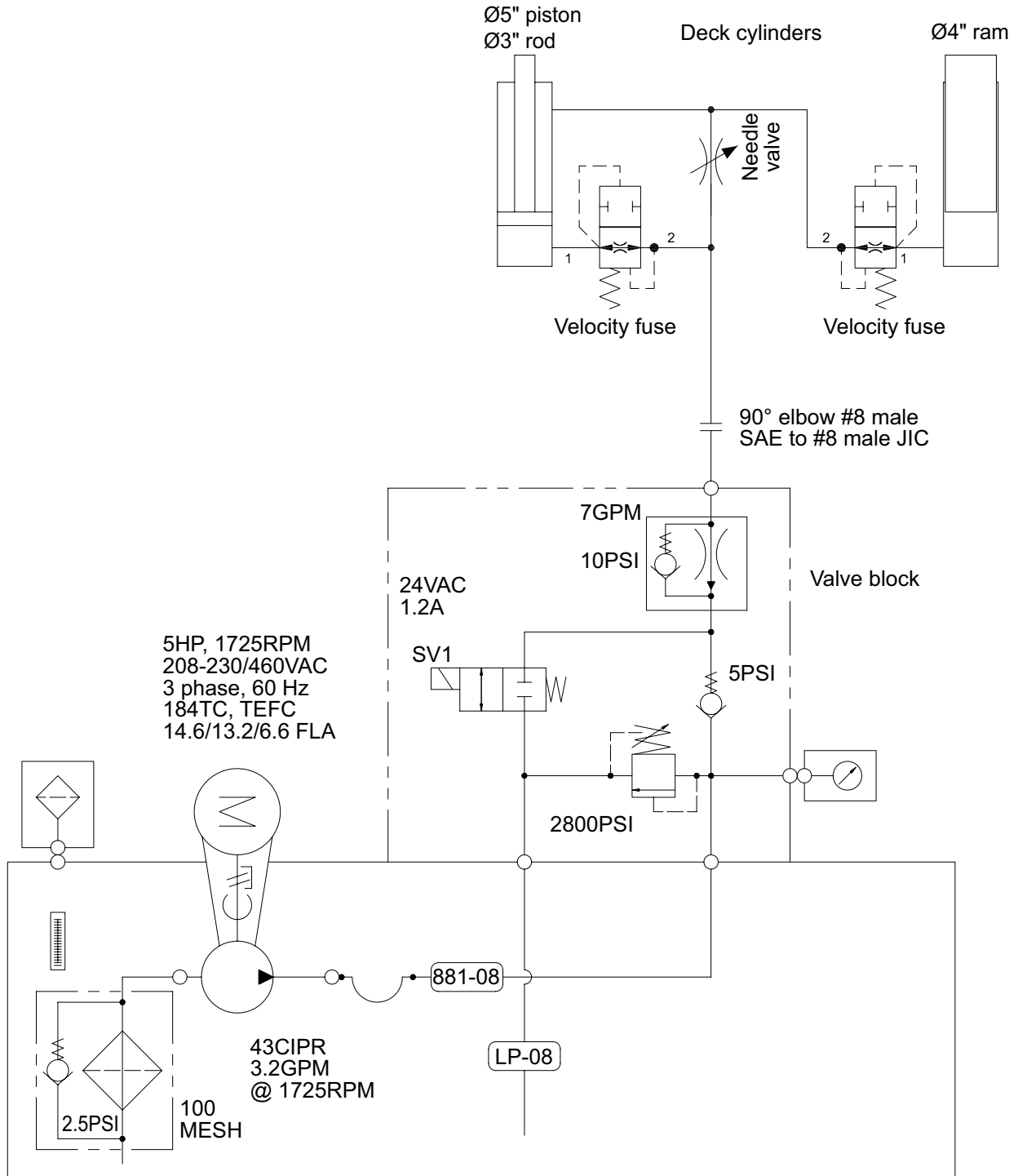

PARTS LIST — TRUCK LEVELER

⚠ WARNING

To ensure proper function, durability and safety of the product, only 4Front original replacement parts must be used. Incorporation of replacement parts or modifications that weaken the structural integrity of the product, or in a way alter the product from its normal working condition at the time of purchase from 4Front Engineered Solutions could result in product malfunction, breakdown, premature wear, death or serious injury.

Fig. 17

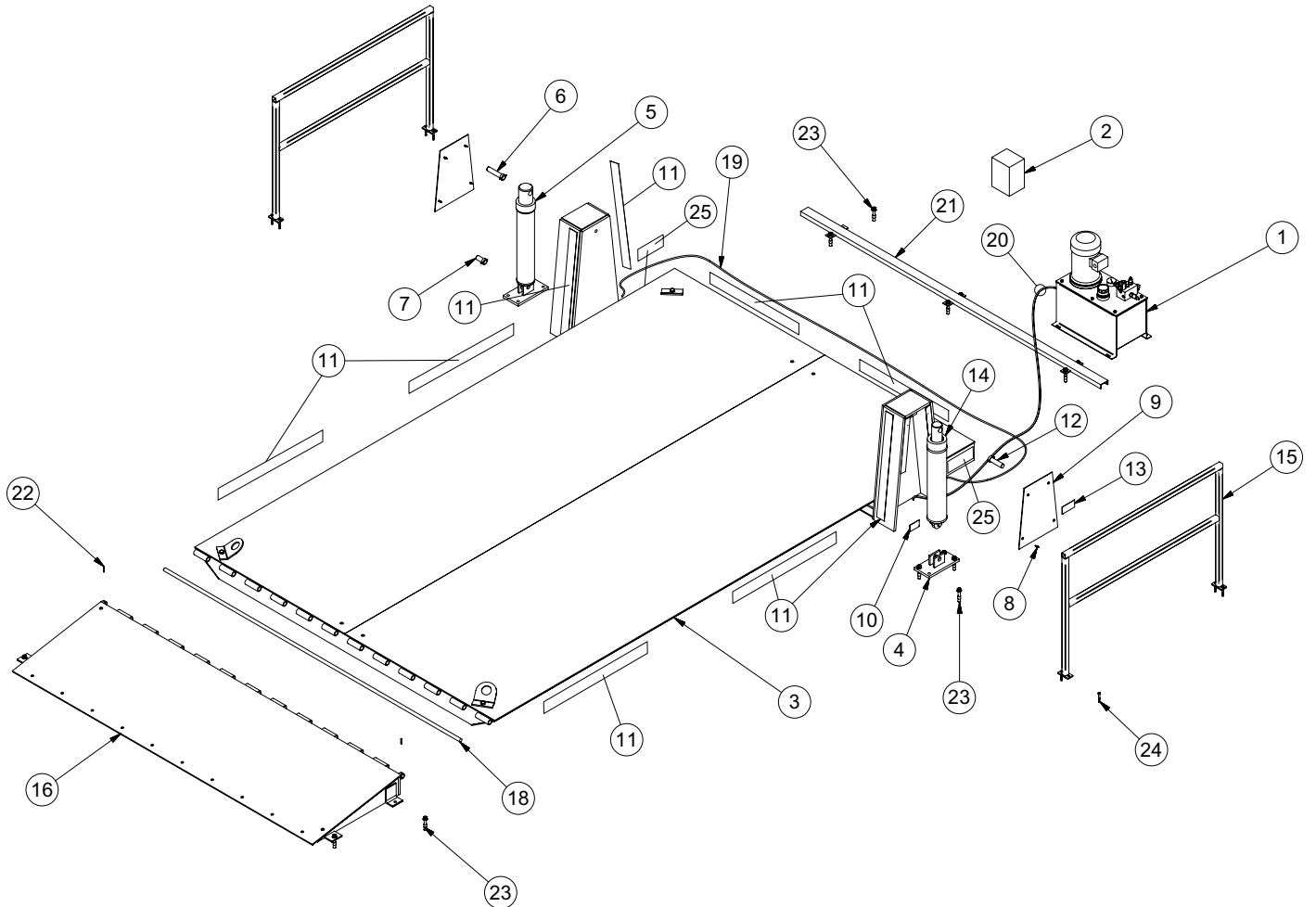

PARTS LIST — TRUCK LEVELER, continued

Item	Quantity	Description	Part Number
1	1	POWER UNIT ASSEMBLY	380-382
2	1	CONTROL PANEL ASSEMBLY	6010210
3	1	DECK ASSEMBLY TL 1014 (24" TRAVEL) TL 1014 (36" TRAVEL) TL 1016 (24" TRAVEL) TL 1016 (36" TRAVEL) TL 1020 (24" TRAVEL) TL 1020 (36" TRAVEL)	380-389 380-587 380-588 380-596 380-586 380-600
4	2	CYLINDER BASE PLATE ASSEMBLY	380-215
5	1	CYLINDER ASSEMBLY, 4" RAM 24" TRAVEL (STANDARD) 36" TRAVEL (OPTIONAL)	6010127 6010137
6	1	TOP RAM PIN ASSEMBLY - 4" CYLINDER	380-208
7	2	BOTTOM RAM PIN ASSEMBLY	6010122
8	8	10-16 X 1"LG. TEK SELF-DRILLING SCREW	040-008
9	2	CYLINDER ENCLOSURE COVER PLATE 24" TRAVEL (STANDARD) 36" TRAVEL (OPTIONAL)	380-227 380-624
10	1	SERIAL TAG	6009761
11	10	LABEL - HAZARD WARNING, 35"	138-837
12	1	TOP RAM PIN – 3" CYLINDER	380-210
13	2	BRAND LABEL SERCO KELLEY	921-243 921-236
14	1	CYLINDER ASSEMBLY, 5" PISTON, 3" ROD 24" TRAVEL (STANDARD) 36" TRAVEL (OPTIONAL)	6010128 6010138
15	2	GUARD ASSEMBLY	380-218
16	1	RAMP ASSEMBLY – 3 FOOT (SM UNITS ONLY)	380-247
17	1	REAR HINGE ANGLE ASSEMBLY (PM UNITS ONLY)	380-186
18	1	HINGE ROD	380-189
19	1	HOSE ASSEMBLY, #6 X 20'	380-555
20	1	HOSE ASSEMBLY, #8 X 39'	380-550
21	1	REAR HOSE GUARD ASSEMBLY (SM UNITS ONLY)	380-499
22	2	ROLL PIN 1/4 X 1-3/4	6010126
23	18	ANCHOR 5/8 X 4-1/2	131294
24	8	ANCHOR 3/8 X 3	6009399
25	2	LABEL - HAZARD WARNING, 12"	6008555

PARTS LIST — CONTROL PANEL

Fig. 18

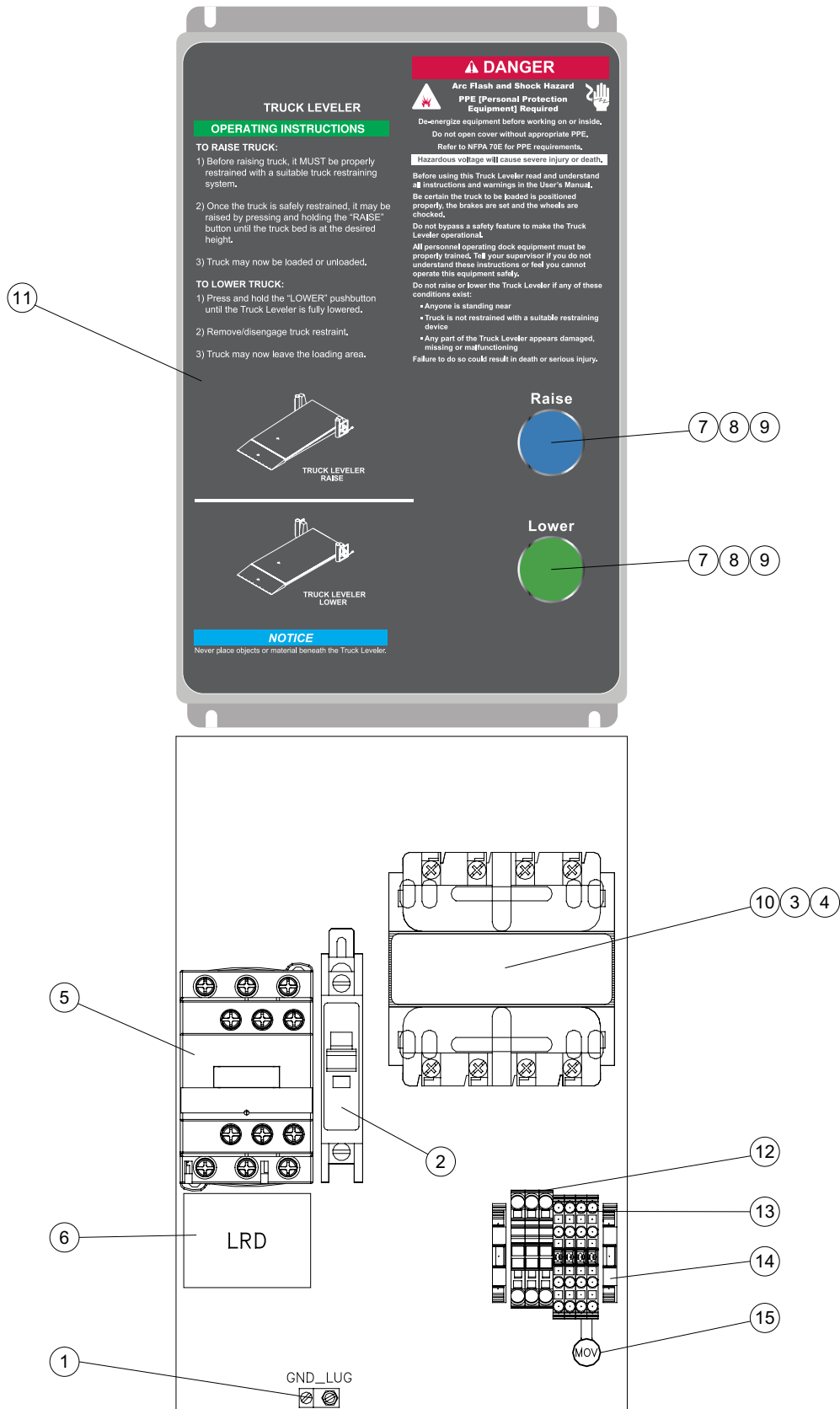

PARTS LIST — CONTROL PANEL, continued

460V/3PH/50-60Hz

Item	Quantity	Description	Part Number
1	1	Ground bar	6000559
2	1	Circuit protector, thermal, 1-pole, 2 amp	6000495
3	1	Block, fuse, 2 pole, fingersafe	6006850
4	2	Fuse, time delay	FU109
5	1	IEC contactor, non-reversing, 24VAC, 3-pole, +1NO+1NC, 1-15HP/18A	6000467
6	1	Overload relay, 5.5-8 Amp	6000476
7	2	Push button, momentary, NEMA 4/4x/13	6000506
8	2	Body, mounting collar	6000515
9	2	Block, contact, N.O.	632-228
10	2	Xfmr, 240/480V to 24V, 50VA	XF111V
11	1	Control panel label Serco Kelley	6010147 6010146
12	3	Terminal block	6007888
13	4	Terminal block	6000542
14	2	End stop	6000549
15	1	Suppressor	6006852

NOTE:

This parts list is for 460V/3PH/50-60Hz only. For other voltages consult factory.

See table on page 16 for class CC fuse size.

PARTS LIST — HYDRAULIC POWER UNIT

Fig. 19

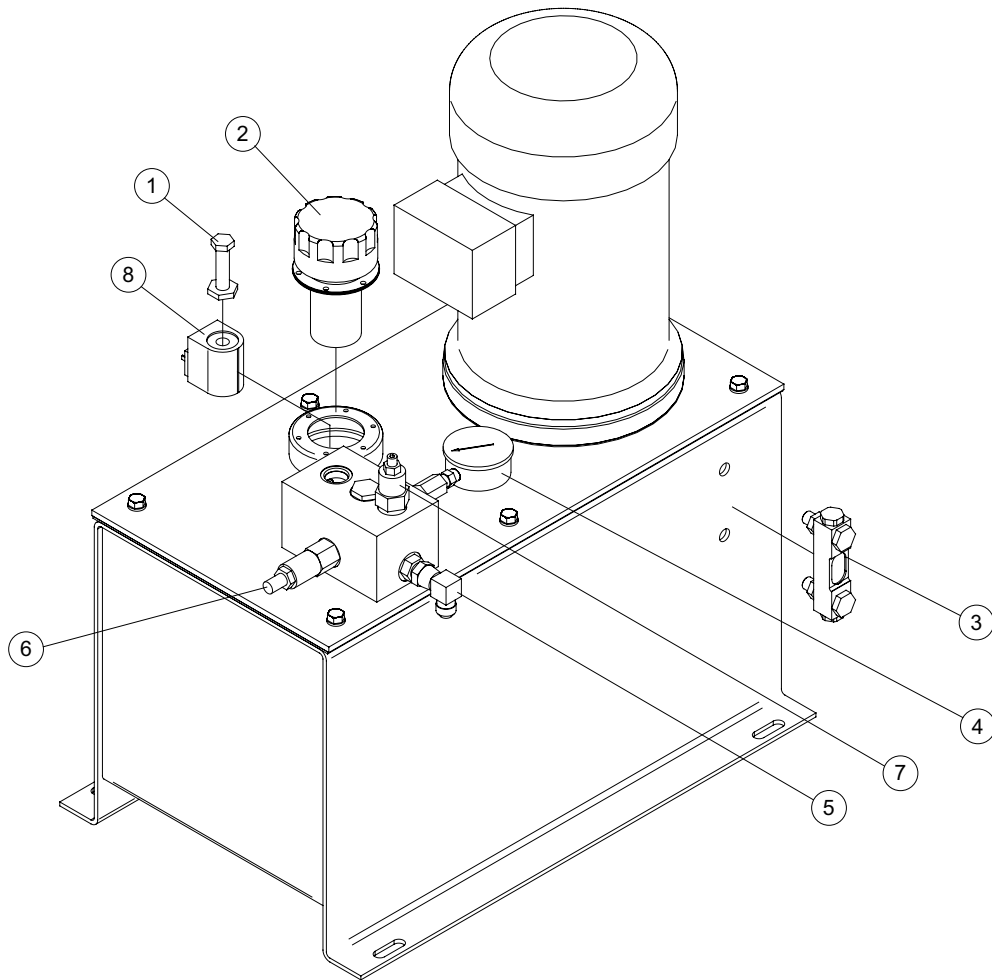

PARTS LIST — HYDRAULIC POWER UNIT, continued

Item	Quantity	Description	Part Number
1	1	VALVE CARTRIDGE	024167
2	1	FILLER BREATHER	033013
3	1	SIGHT GAUGE	033028
4	1	GAUGE 0-4000 PSI	033022
5	1	ELBOW, 1/2" M NPT TO #8 M JIC	026076
6	1	PRESSURE RELIEF VALVE	024165
7	1	FLOW CONTROL VALVE	024015
8	1	SOLENOID COIL	024104

NOTES

LIMITED WARRANTY

4Front Engineered Solutions, Inc. warrants that this truck leveler will be free from defects in material and workmanship under normal use for a period of one (1) year from the earlier of 1) 60 days after the date of initial shipment by 4Front Engineered Solutions, Inc., or 2) the date of installation of the truck leveler by the original purchaser, provided that the owner maintains and operates the truck leveler in accordance with this Owner's Manual.

In the event that this truck leveler proves defective in material or workmanship within the warranty period, 4Front Engineered Solutions, Inc. will, at its option:

1. Replace the truck leveler, or the defective portion of either, without charge to the owner (excluding any cost of removal or reinstallation which shall be the sole responsibility of the of the purchaser); or
2. Alter or repair the truck leveler, on site or elsewhere, without charge to the owner.

This warranty IS EXCLUSIVE AND IT IS IN LIEU OF ANY OTHER GUARANTEES OR WARRANTIES, EXPRESS OR IMPLIED. THERE ARE NO WARRANTIES, EXPRESS OR IMPLIED, WHICH EXTEND BEYOND THE DESCRIPTION ABOVE AND THERE IS NO WARRANTY OF MERCHANTABILITY OR OF FITNESS FOR A PARTICULAR PURPOSE. 4Front Engineered Solutions, Inc. sole warranty obligation with regard to this truck leveler shall be as set forth above.

This warranty does not cover any failure caused by improper installation, abuse, negligence, or failure to properly maintain and adjust the truck leveler. Parts requiring replacement due to damage resulting from vehicle impact, abuse, or improper operation are not covered by this warranty. 4Front Engineered Solutions, Inc. disclaims any responsibility or liability for any loss or damage that results from the use of unauthorized replacement parts or modification of the truck leveler.

Please direct questions about your Truck Leveler to your local distributor.

Your local distributor is:

Corporate Head Office:

1612 Hutton Dr. Suite 140

Carrollton, TX. 75006

Tel. (972) 466-0707

Fax (972) 323-2661