

Manual and Automatic Light Communication Systems

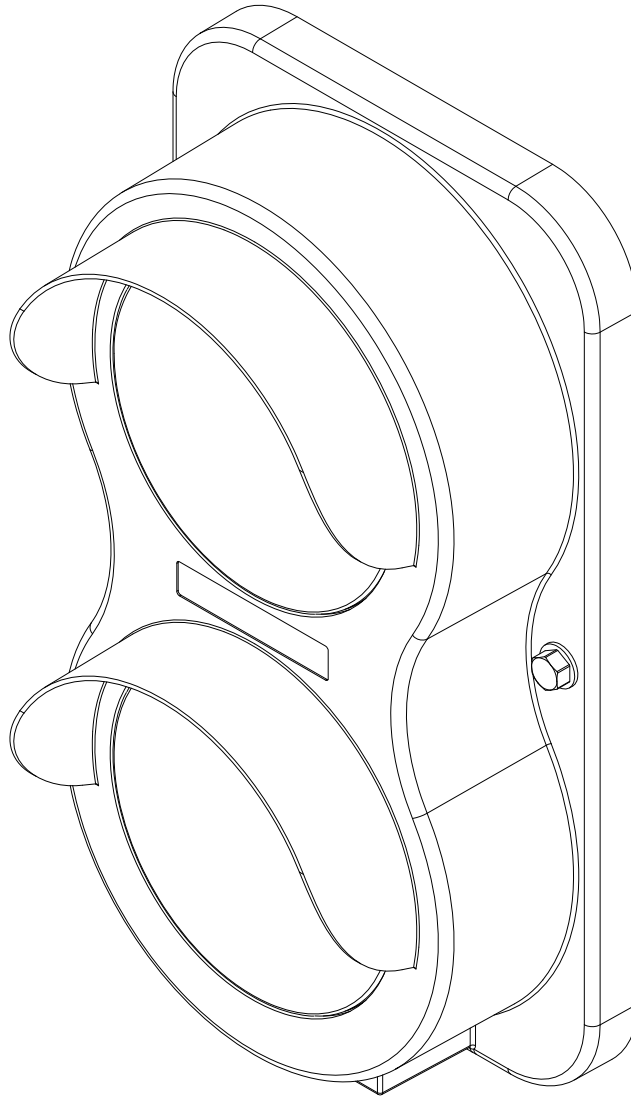

This manual applies to MLS/ALS
units manufactured beginning
February 1, 2013.

▲ WARNING

Do not install, operate or service this product unless you have read and understand the Safety Practices, Warnings, Installation and Operating Instructions contained in this User's Manual. Failure to do so could result in death or serious injury.

User's Manual Installation, Operations, Maintenance and Parts

Part No. 6005099C

TABLE OF CONTENTS

Table of Contents.....	2	Wiring Diagram —ALS2	21
Introduction.....	2	Operating Instructions — AMLS	22
Safety Signal Words	2	Wiring Diagram —AMLS	26
Safety Practices.....	3	Operating Instructions — MLS	27
Installation	4	Wiring Diagram —MLS	29
Operating Instructions	8	Parts List.....	31
Operating Instructions — ALS1	9	Warranty Information	35
Wiring Diagram —ALS1	14	Distributor Information	36
Operating Instructions — ALS2	15		

INTRODUCTION

Welcome and thank you for choosing this light system.

This User's Manual contains information that you need to safely install, operate and maintain the light system. It also contains a complete parts list and information about ordering replacement parts. Please keep and read this User's Manual before using your new light system.

SAFETY SIGNAL WORDS

You may find safety signal words such as DANGER, WARNING, CAUTION or NOTICE throughout this User's Manual. Their use is explained below:



This is the safety alert symbol. It is used to alert you to potential personal injury hazards. Obey all safety messages that follow this symbol to avoid possible death or injury.

▲ DANGER

Indicates an imminently hazardous situation which, if not avoided, will result in death or serious injury.

▲ CAUTION

Indicates a potentially hazardous situation which, if not avoided may result in minor or moderate injury.

▲ WARNING

Indicates a potentially hazardous situation which, if not avoided, could result in death or serious injury.

NOTICE

Notice is used to address practices not related to personal injury.

⚠ WARNING

Read these safety practices before installing, operating or servicing the light system. Failure to follow the safety practices could result in serious injury or death.

READ AND FOLLOW THE INSTRUCTIONS CONTAINED IN THIS MANUAL BEFORE INSTALLING, OPERATING OR SERVICING THE LIGHT SYSTEM. If you do not understand the instructions, ask your supervisor to teach you how to use the light system or call your local distributor.

Improper installation of the light system could result in death or serious injury to dock workers or other users of the light system.

Be certain to follow the installation instructions in this manual.

INSTALLATION AND OPERATION

Use by untrained people can cause property damage, bodily injury and/or death. Your supervisor should teach you the safe and proper way to use the light system. Read and follow the complete OPERATION INSTRUCTIONS for your model found in this User's Manual before use. DO NOT USE THE LIGHT SYSTEM IF IT IS NOT WORKING CORRECTLY. Tell your supervisor it needs repair.

Always CHOCK TRUCK WHEELS or lock the truck to the dock with a truck restraint, and set the vehicle brakes before loading or unloading the truck.

If during the installation, operation, or maintenance of the light system, there are any questions about the operation, performance or procedures, contact your supervisor or your local distributor for clarification and/or repair.

Before chocking wheels or engaging vehicle restraint, dump air from air ride suspensions and set parking brake.

MAINTENANCE AND SERVICE

Place barricades around pit on dock floor and drive while installing, maintaining or repairing the light system.

Do not stand in the driveway between the dock and backing truck.

All electrical troubleshooting and repair must be done by a qualified technician and meet all applicable codes.

Before doing any electrical work (including changing bulbs), make certain the power is disconnected and properly tagged or locked off.

INSTALLATION

STANDARD WALL MOUNTING PROCEDURE

NOTE:

Refer to wiring diagram found in this User's Manual for your model of light system for all field wiring connections between control panel, outside light and any interlocking switches.

1. Mount control panel inside the building 5 feet above the floor, just to the left of the doorway from inside. See Fig. 2.
2. Mount and wire outside 24V signal light assembly to the control panel using terminals "Outside R" for red, "Outside G" green, and "Outside +" for common on the terminal strip in the control panel. Always mount the light assembly with the red light on top and the green light on the bottom. See Fig. 1 and 2.

⚠ WARNING

Do not install, operate or service this product unless you have read and followed the Safety Practices, Warnings, and Installation and Operation Instructions in this manual. Failure to do so could result in death or serious injury.

3. Permanently mount the vehicle driver's instruction sign on the outside wall (below the signal light when installing RED/GREEN Light Assembly). See Fig. 2.

Fig. 1

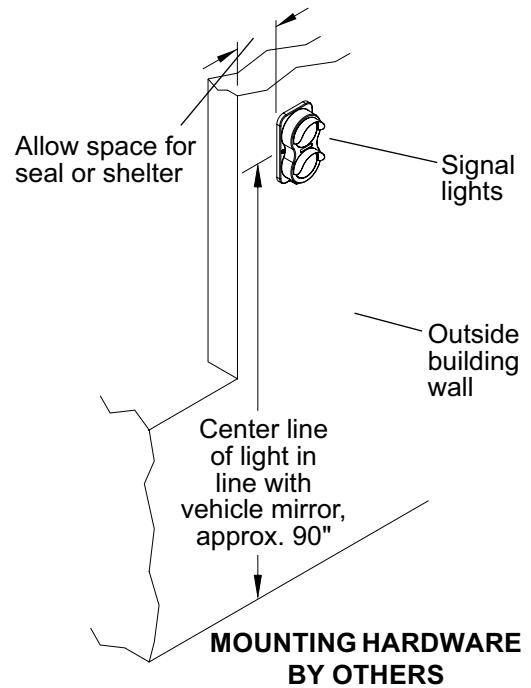
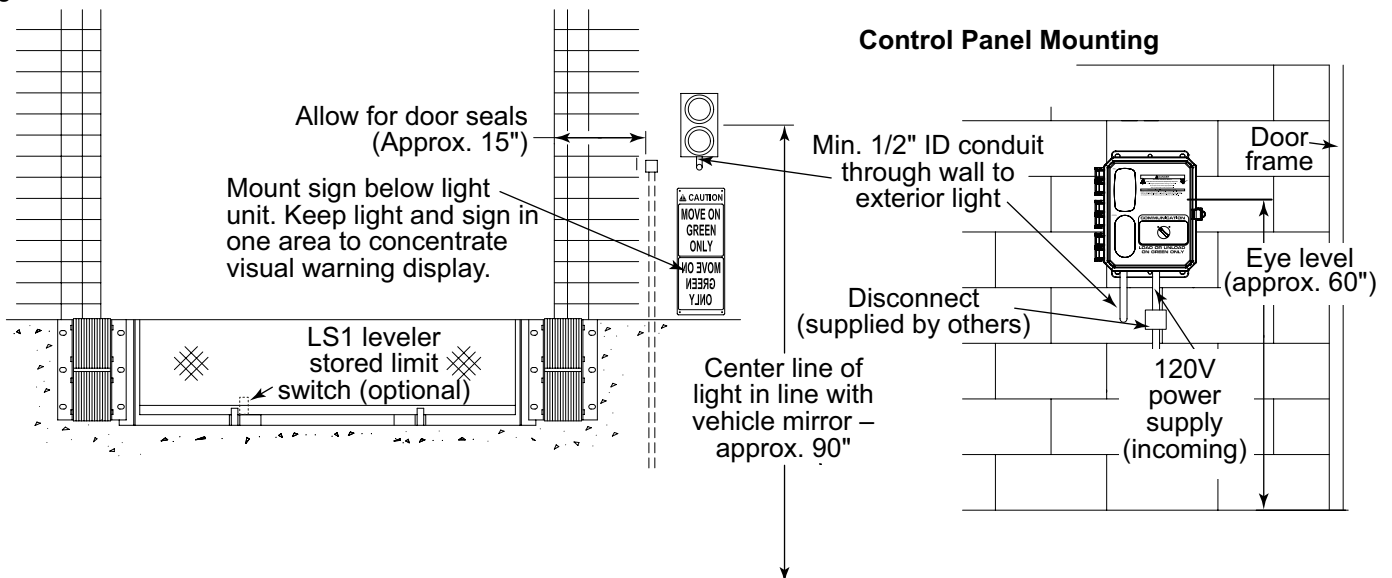

Fig. 2



Refer to the proper steps below for your model of light system.

There are two standard “ALS” systems available. In this manual they are called “ALS1” and “ALS2”. The ALS1 system has a single switch that allows the lights to operate by a door opened or a dock leveler stored sensor to switch the lights automatically. The ALS2 system has two switches that allow the lights to become operated by either: door opened AND leveler stored sensor; or door opened AND door closed sensors .

The “AMLS” has a single switch that allows the outside light to be operated by either a door opened sensor or a dock leveler stored sensor while the inside lights are operator controlled by a switch on the control panel by the dock worker.

The “MLS” is a completely manual light system where the lights are controlled through a switch on the control panel by the dock worker.

For MLS light systems (6014248, 6014249) skip to installation step 9. See pages 27-30.

For ALS1 systems (6013947, 6013949) with single limit switch interconnect proceed to installation step 4. See pages 7-14.

For ALS2 systems (6014244, 6014245) with dual limit switch interconnect proceed to installation step 6. See pages 15-20.

For special AMLS systems (6014246,6014247) with single limit switch proceed to installation step 8. See pages 21-25.

NOTE:

If a powered door operator is present, recommend using auxiliary dry contact (piggyback) door opened and door closed limit switches. These are supplied by the door operator manufacturer.

4. On ALS1 systems (6013947, 6013949) mount either a door opened limit switch 625-208 OR a leveler stored limit switch (625-203) and bracket (5862417) for Serco units or lip switch kit (908877) for Kelley units, each sold separately, and wire per wiring diagram on page 14.

NOTE:

If a leveler stored switch is used on ALS1 systems, change the DIP switch setting on DIP switch 1 on “ON”. See page 14.

5. Proceed to step 9.

6. For ALS2 systems (6014244, 6014245) there are two options for control.
 - a. Option 1 — Mount BOTH a door opened limit switch 625-208 (to sense the door fully opened) AND a leveler stored limit switch (625-203) and bracket (5862417) for Serco units or lip switch kit (908877) for Kelley units, each sold separately, and wire per wiring diagram on page 20. Change the DIP switch setting on DIP switch 1 to “ON”. See page 20.
 - b. Option 2 — Mount BOTH a door closed limit switch 625-208 (to sense the door fully closed) AND a door opened limit switch 625-208 (to sense the door fully opened) each sold separately and wire per the wiring diagram on page 20.
7. Proceed to step 9.
8. For AMLS systems (6014246, 6014247) with single limit switch, mount a door opened limit switch 625-208 (sold separately) and wire per the wiring diagram on page 25.

NOTE:

Some of these control panels contain a dry-contact interlock output (terminals 15 and 16) which can be wired into an interlock capable dock leveler’s control panel circuit. The dock leveler control circuit must not exceed 120VAC, and an external 2.0 amp fuse (by others) must be provided.

▲ DANGER

Before doing any electrical work, make certain the power is disconnected and properly locked or tagged off.

Failure to do so may result in death or serious injury. All electrical work must be done by a qualified technician and must meet all applicable codes.

Do not route control wiring for any other device through this control panel unless properly shielded.

Be certain power is off when wiring to the control panel or signal lights. Failure to do so could result in electrical shock, death or serious injury.

9. Wire power to the control panel through a fused disconnect (supplied by others) using terminals provided in the control panel. See wiring diagram for your model light system located in this User’s Manual. Turn the power on.

INSTALLATION, continued

10. Check for proper operation. The proper lights must be on, inside and outside, at all times. Operate the light system following the operating instructions located in this User's Manual for your model light system. Check for proper operation according to the operating instructions and optional interlocking installed.
11. If the light system does not operate properly, TURN OFF POWER TO LIGHTS and rewire as required. Repeat step 10 above.
12. When you have tested the system and it is operating properly, instruct the dock workers how to use the light system using the appropriate operating procedures located in this User's Manual for the corresponding model light system.
13. If a powered dock leveler is installed, the dock leveler control circuit can be interrupted and wired through the leveler interlock terminals IL1 and IL2 (0.5A@24V max) or 15 and 16 (2A@120V max) in the control panel, depending on your model of light system. See wiring diagrams.

LEVELER STORED SENSOR INSTALLATION

NOTE:

A Leveler Stored sensor can be mounted beneath Serco hydraulic dock levelers that have lip keepers (except PAL), as shown in Fig. 3. For all others, call your authorized distributor. Kelley products, that have lug hinges and do not have lip keepers, use a lip mounted switch kit 908-877. Install instructions are part of the kit.

FOR SERCO DOCK LEVELERS

1. Leveler sensor switch installation: Install the leveler stored sensor bracket. Attach the face of the sensor so when the lip is stored the face of the sensor is 3/4" from lip for 6' and 8' levelers and 1" for 10' levelers. See Fig. 3.
2. The switch is supplied with a four conductor cable. Only 3 of these conductors will be used. A junction box must be installed beneath the leveler to protect the connections.
3. Connect the BROWN wire to terminal "+". Connect the BLUE wire to terminal "0V". Connect the BLACK wire to the input terminal. Move the DIP switch #1 to the "ON" position.
 - a. The control circuit board input I3 LED will illuminate when the leveler is in the stored position.

Fig. 3

6' and 8' Levelers

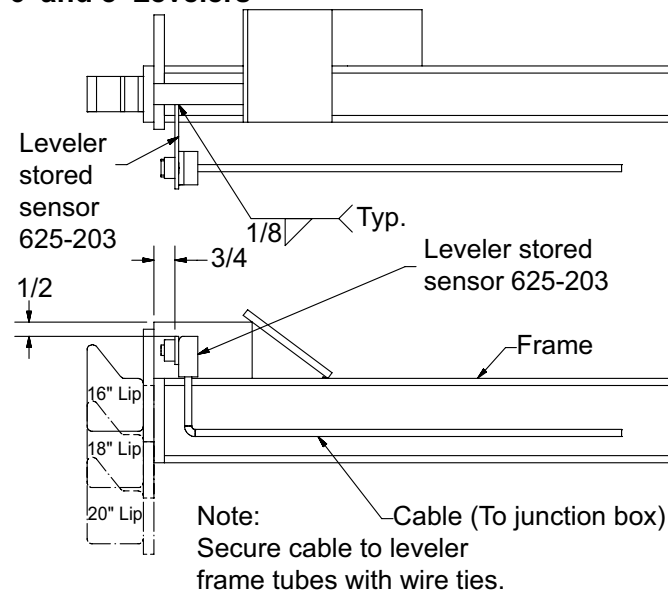

10' Levelers

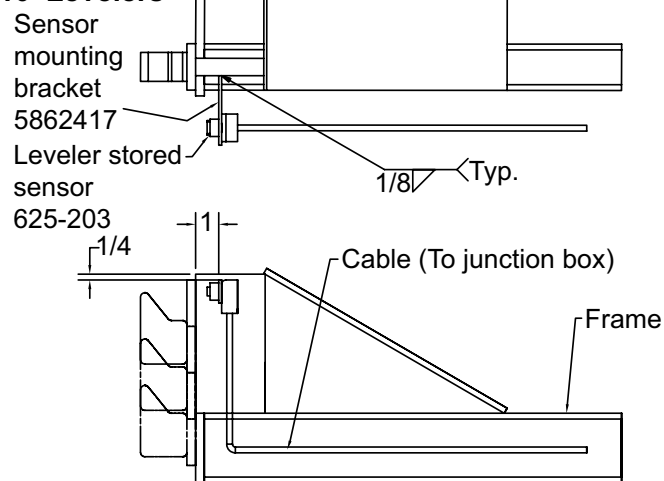

DOOR OPENED AND CLOSED SENSORS INSTALLATION

NOTE:

Door opened and door closed sensors can be installed on manually operated doors with standard track. For powered doors, see note on page 5. See Fig. 4, 7 and 13. For other types of doors, call your authorized distributor.

1. Orient door opened and door closed sensors on the door track as shown in Fig. 13. If the door track cannot be drilled, a sensor mounting bracket may be required.
2. Drill a 3/4" hole through the door track directly beside the door panel. See Fig. 4.
3. Mount the sensor through the hole so it looks directly at the side of the door panel.
4. Neatly route and secure the sensor cables away from all moving door components down the wall to the control panel.
5. Connect the BROWN wire to terminal "+". Connect the BLUE wire to terminal "0V" REPEAT the above for wiring instructions for the door closed sensor. Wire the white OR black wire to the proper input terminal per the wiring diagram for the product being installed. See wiring diagrams. Optimal sensing distance of the switch is approximately 2".

Fig. 4

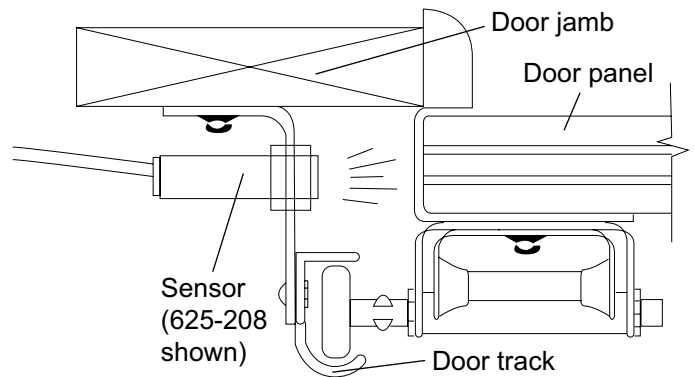

OPERATION INSTRUCTIONS

⚠ WARNING

Before operating the light system, read and follow the Safety Practices, Warnings, and Operation instructions contained in this manual. Use by untrained people could result in death or serious injury.

Do not use the light system if it looks broken or does not seem to work right. Tell your supervisor right away.

Vehicles not restrained move unexpectedly. Vehicles leaving or moving when loading and unloading are in process could result in death or serious injury.

Do not load or unload any vehicle unless you make certain a vehicle restraint or wheel chock has securely restrained the vehicle and set the brakes.

Before chocking wheels or engaging vehicle restraint, dump air from air ride suspensions and set parking brakes.

Enter vehicle only after making certain the vehicle is restrained (or chocked) and the light controls indicate a GREEN inside light and brakes are set. Vehicles not restrained move unexpectedly. If the lights are not properly switched the vehicle driver will see a GREEN light and could pull out unexpectedly.

Fig. 5

OUTSIDE LIGHTS AND SIGN

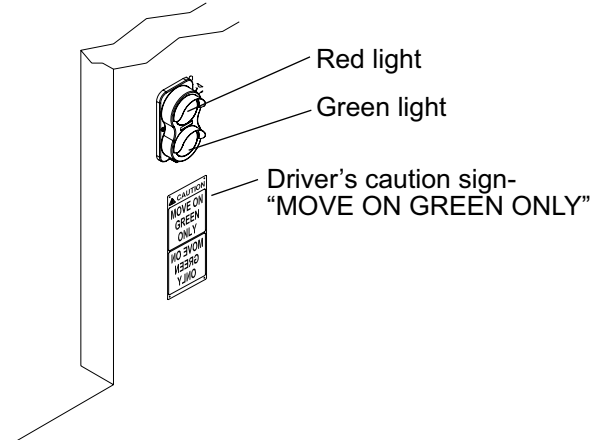

CONTROL PANEL

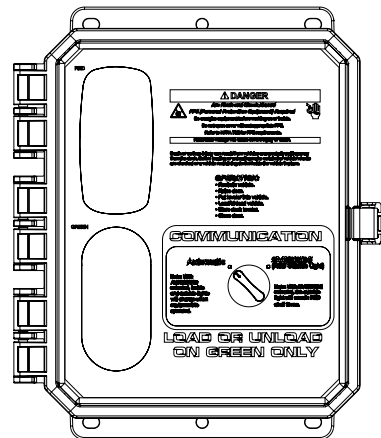

OPERATION INSTRUCTIONS — ALS1

Simplified Instructions

ALS1 (SERCO P/N 6013947; KELLEY P/N 6013949) Fig. 6

1. Restrain vehicle (with vehicle restraint or wheel chocks).

▲ WARNING

Before loading or unloading make certain that the vehicle wheels are chocked or a vehicle restraining device holds the vehicle in place.

2. Raise door.

- If a door opened limit switch is used, the inside light will change to solid Green and the outside light will change to flashing Red when the door is opened.
- If interlock output is wired into a dock leveler controller, the leveler control circuit is now enabled.

3. Put dock leveler into vehicle.

- If a leveler stored switch is used instead of a door opened switch, the inside light will change to solid Green and the outside light will change to flashing Red when the leveler lip is positioned outside the lip keepers (i.e. outside the storage position)
- When interlocked to a leveler stored switch, the auxiliary interlock contacts are now closed.

4. Load/Unload vehicle.

5. Store dock leveler.

- If a leveler stored switch is used instead of a door opened switch, the inside light will change to solid Red and the outside light will change to flashing Green when the leveler is returned to its stored position.
- When interlocked to a leveler stored switch, auxiliary interlock contacts are now opened.

6. Close Door.

- When interlocked to a door opened switch, and the interlock output is wired to a dock leveler controller, the leveler control circuit is now disabled.
- When interlocked to a door opened switch, dock leveler motor is now disabled.

7. Release manual vehicle restraint or remove manual wheel chocks.

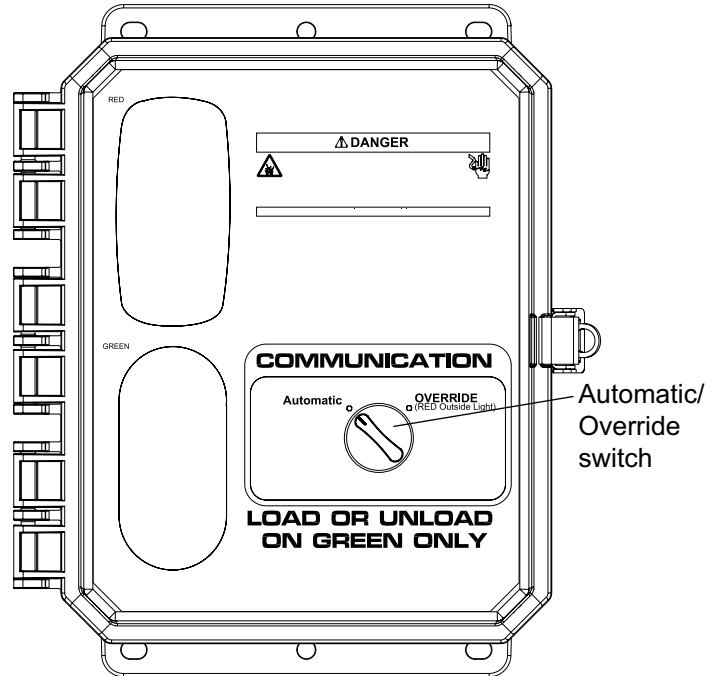

NOTE:

The selector switch “Override (Red Outside Light)” position is only used to force the exterior lights Red when the Leveler is stored. This is used as a signal to outside of the Dock that it is closed and not ready to accept vehicles or to retain vehicles. The selector switch will not illuminate the interior Green light.

The interior Green light will only be on when the Leveler is positioned outside of the lip keepers, (either on the vehicle or in the end loading position) when interlocked with a leveler stored switch; OR when the door is opened, when interlocked with a door opened switch.

OPERATION INSTRUCTIONS — ALS1, continued

Detailed Instructions

ALS1 (SERCO P/N 6013947; KELLEY P/N 6013949) Fig. 7

NOTE:

This control panel has only two approved control options. Any other installation or operation of this equipment must be reviewed and approved by the manufacturer.

INTRODUCTION

A single limit switch closes changing both the inside and outside communications lights automatically. The selector switch can be manually turned to force the outside lights to red but the inside lights will remain Red and the interlock contacts will remain open unless the single limit switch is closed.

NOTE:

Photoelectric limit switch state is open when the door is closed. The limit switch contacts close when the door is opened. (switch no longer "SEES" the door)

OPTION 1:

LS1 = Door Open Switch (625-208) - When the dock door is opened the inside lights switch to display solid Green, the outside lights switch to display flashing Red and the Interlock terminals IL1-IL2 close.

1. Restrain vehicle (with vehicle restraint or wheel chocks).

⚠ WARNING

Before loading or unloading make certain that the vehicle wheels are chocked or a vehicle restraining device holds the vehicle in place.

2. Raise/Open Door

- When the door is opened, LS1 closes and the inside light will change to solid Green and the outside light will change to flashing RED.
- The LED's for I3 and IL illuminate.
- If the Interlock output is wired into a Dock Leveler controller, dock leveler and leveler control circuit is now enabled.

3. Position Dock Leveler into vehicle.
4. Load/Unload vehicle.
5. Restore dock Leveler to the stored position.

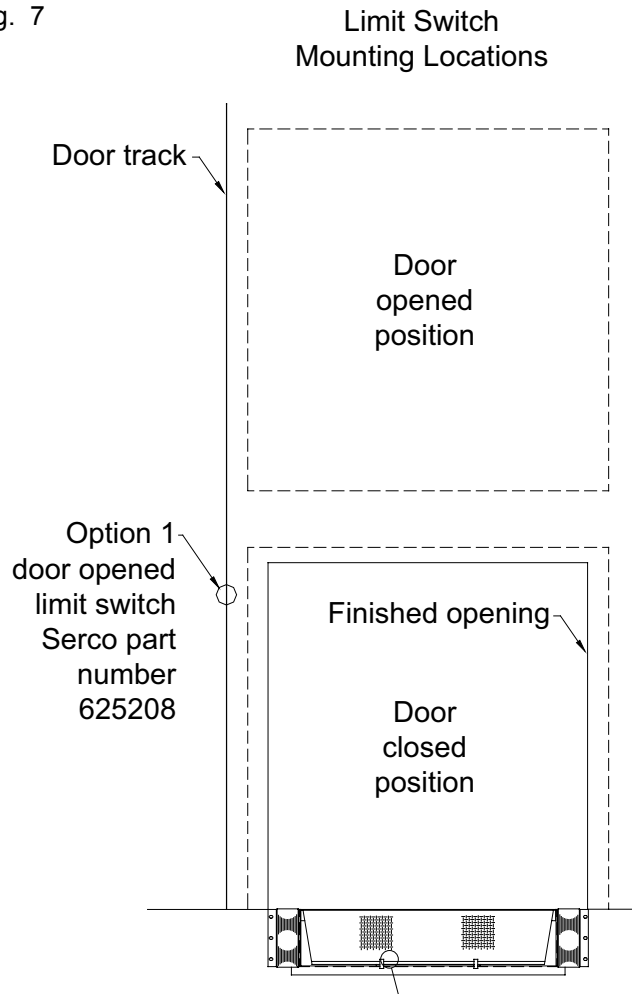
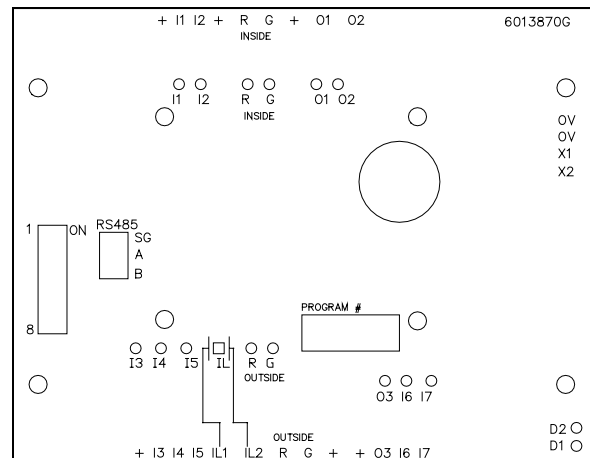

Fig. 8



OPERATION INSTRUCTIONS — ALS1, continued

Detailed Instructions

6. Lower/Close Door.

- When the door is closed, LS1 opens and the inside light will change to solid Red and the outside light will change to flashing Green.
- The LED's for I3 and IL extinguish.
- If the Interlock output is wired into a Dock Leveler controller, dock leveler and leveler control circuit is now disabled.

7. Release manual vehicle restraint or remove manual wheel chocks.

OPTION 2:

LS1 = Leveler Stored Switch (625-203) - When the leveler is removed from the stored position the inside lights switch to display solid Green, the outside lights switch to display flashing Red and the Interlock terminals IL1-IL2 close.

NOTE:

Photoelectric limit switch state is closed when the Leveler is stored. The limit switch contacts open when the Leveler is NOT in the stored position.

1. Restrain vehicle (with vehicle restraint or wheel chocks).

▲ WARNING

Before loading or unloading make certain that the vehicle wheels are chocked or a vehicle restraining device holds the vehicle in place.

2. Raise/Open Door

3. Position Dock Leveler into vehicle.

- When the lip is positioned outside the lip keepers (outside the stored position) the inside light will change to solid Green and the outside light will change to flashing RED.
- The LED for I3 will extinguish. The IL LED will illuminate.
- Interlock contacts IL1-IL2 are now closed.

4. Load/Unload vehicle.

Fig. 9

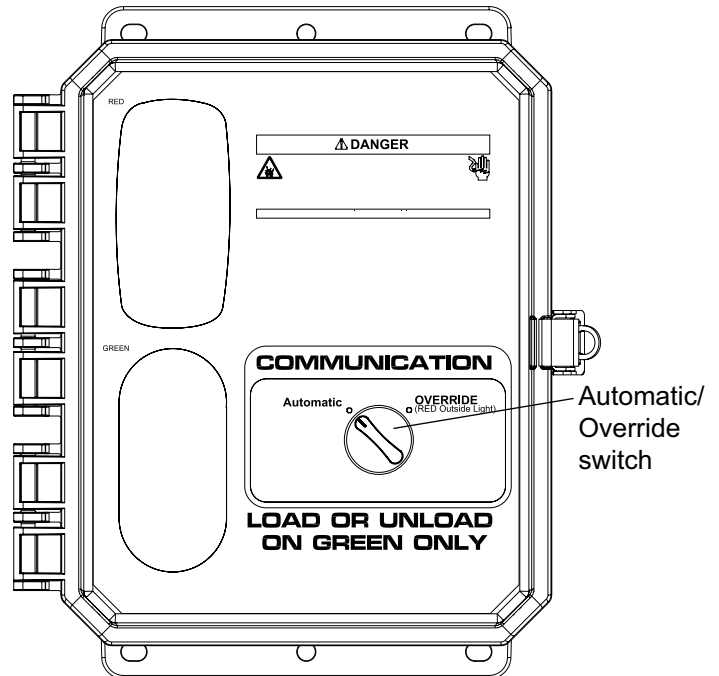

NOTE:

The selector switch "Override (Red Outside Light)" position is only used to force the exterior lights Red when the Leveler is stored. This is used as a signal to outside of the Dock that it is closed and not ready to accept vehicles or to retain vehicles. The selector switch will not illuminate the interior Green light.

There are two ways to activate the interior Green light. They depend on the type of interlocking employed.

1. When interlocked with a leveler stored switch — when the Leveler is positioned outside the lip keepers, (either on the vehicle or in the end loading position) or
2. When interlocked with a door opened switch — when the door is opened.

OPERATION INSTRUCTIONS — ALS1, continued

Detailed Instructions

5. Restore dock Leveler to the stored position.
 - When the leveler lip is positioned into the lip keepers. (i.e. leveler stored position), LS1 closes and the inside lights change to solid Red and the outside light will change to flashing Green.
 - The LED for I3 will illuminate and the LED for IL will extinguish.
 - Interlock contacts IL1-IL2 are now open.
6. Lower/Close Door.
7. Release manual vehicle restraint or remove manual wheel chocks.

ALS1 LOGIC CHART

Option 1 (Door Opened switch): ALS1 DIP1=OFF

Inputs		Outputs				
Selector Switch (I1)	LS1 (I3)	Inside Red	Inside Green	Interlock	Outside Red	Outside Green
Automatic(off)	Door closed/Switch off	X				F
Automatic(off)	Door opened/Switch on		X	X	F	
Override(on)	Door closed/Switch off	X			F	
Override(on)	Door opened/Switch on		X	X	F	

Option 2 (Leveler Stored switch): ALS1 DIP1=ON

Inputs		Outputs				
Selector Switch (I1)	LS1 (I3)	Inside Red	Inside Green	Interlock	Outside Red	Outside Green
Automatic(off)	Leveler stored/Switch on	X				F
Automatic(off)	Leveler not stored/Switch off		X	X	F	
Override(on)	Leveler stored/Switch on	X			F	
Override(on)	Leveler not stored/Switch off		X	X	F	

OPTION 1: LS1 = Door opened Limit Switch (625-208) ON when door is opened.

OPTION 2: LS1 = Leveler Stored Limit Switch (625-203) ON when leveler is stored.

Logic Chart Legend: X = ON F= Flashing

WIRING DIAGRAM — ALS1

ALS1 (SERCO P/N 6013947; KELLEY P/N 6013949)

⚠ DANGER

Before doing any electrical work, make certain the power is disconnected and properly tagged or locked off. All electrical work must be done by a qualified technician and meet all applicable codes. If it is necessary to make troubleshooting checks inside the control box with the power on, USE EXTREME CAUTION. Do not place your fingers or uninsulated tools inside the control box. Touching wires or other parts inside the control box could result in electrical shock, death or serious injury.

Fig. 10

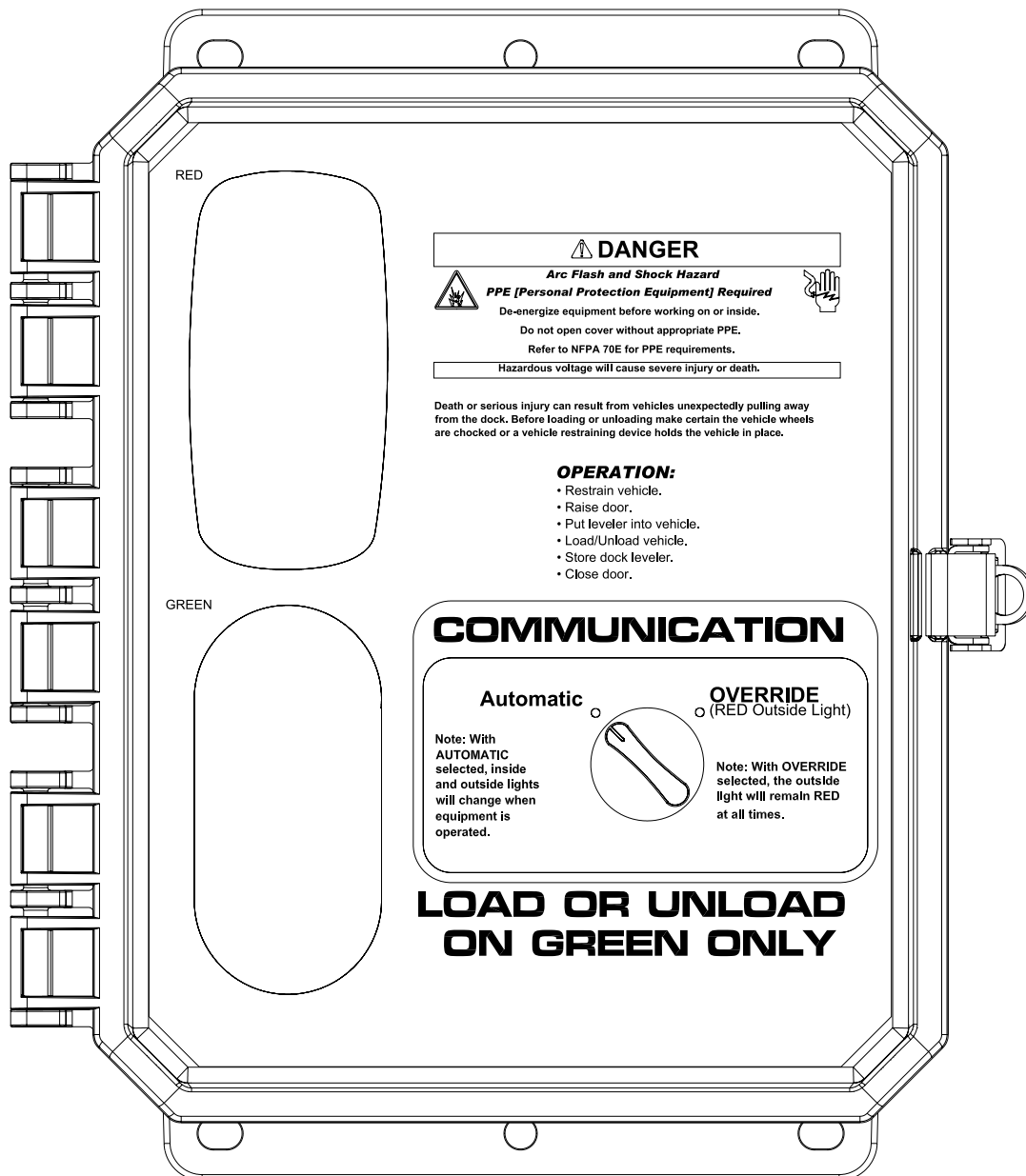

WIRING DIAGRAM — ALS1, continued

ALS1 (SERCO P/N 6013947; KELLEY P/N 6013949)

Fig. 11

120V/1PH/60HZ

CB/FU TO BE SUPPLIED BY OTHERS
 SUPPLY BCPD = CB/FU 15AMP MAX
 PANEL FLA = 0.4AMPS
 SCCR = 5KA

NOTES

1. FIELD TERMINAL WIRING: 90 DEGREE WIRE, MIN 16AWG FOR SIGNAL WIRING, MIN 14AWG FOR INCOMING POWER, SEE CHART IN PANEL FOR TORQUE REQUIREMENTS
2. INTERLOCK 1: TERMINALS IL1-IL2, DRY CONTACT RATED 1/2A @ 24VDC MAX. EXTERNAL FUSE REQUIRED.
3. IF A 3 WIRE DC SWITCH IS USED CONNECT 0V FROM THE SWITCH TO THIS TERMINAL
4. IF USING OPTION 2 LS1=LEVELER STORED , USE THE BLACK WIRE ON THE SWITCH INSTEAD OF WHITE

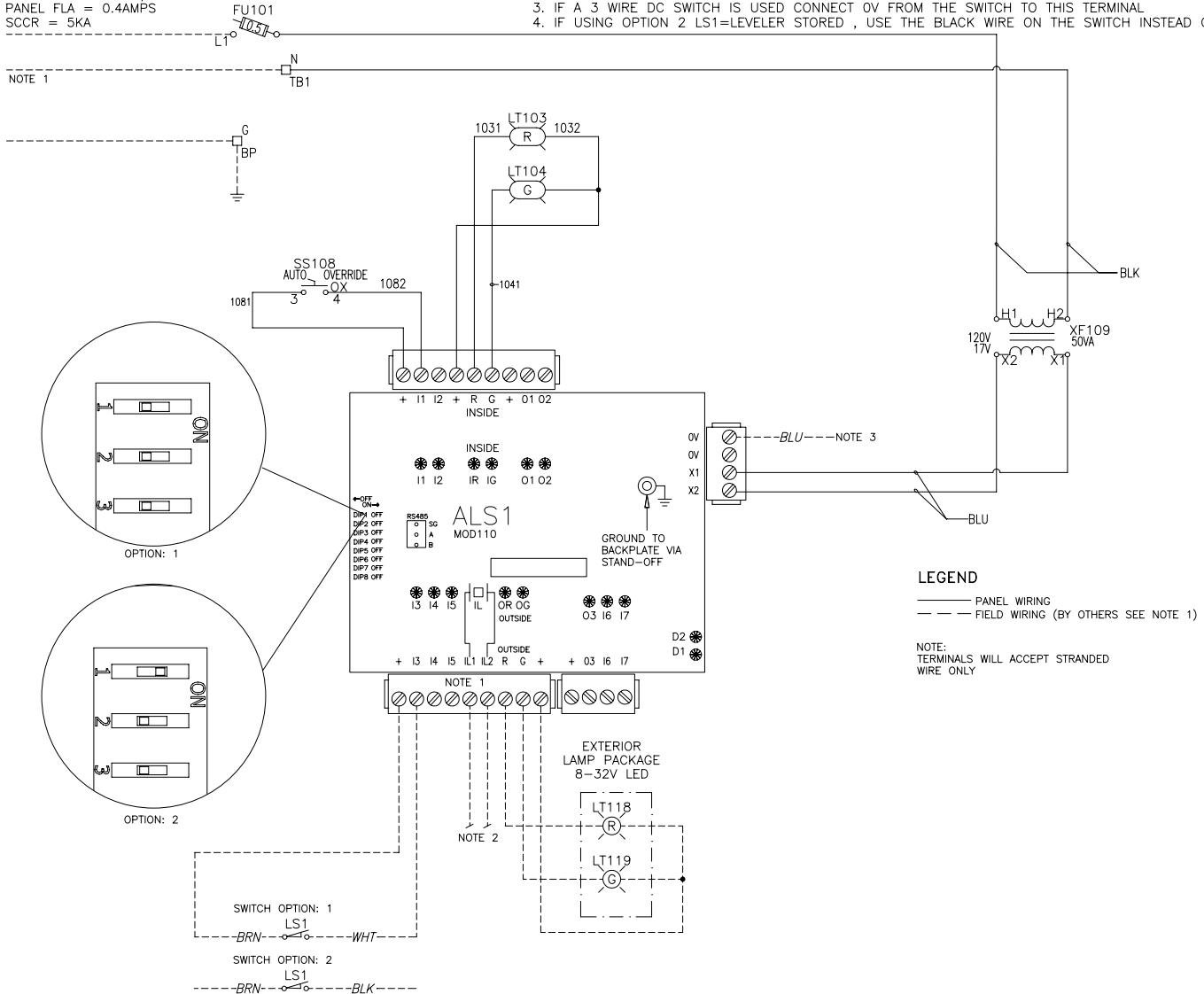

SWITCH OPTIONS

- 1) LS1 = DOOR OPEN SWITCH--WHEN THE DOCK DOOR IS OPENED THE INSIDE LIGHTS SWITCH TO DISPLAY SOLID GREEN, THE OUTSIDE LIGHTS SWITCH TO DISPLAY FLASHING RED AND INTERLOCK IL1-IL2 CLOSES. PART # 625208.
- 2) LS1 = LEVELER STORED SWITCH--WHEN THE LEVELER IS REMOVED FROM THE STORED POSITION THE INSIDE LIGHTS SWITCH TO DISPLAY SOLID GREEN, THE OUTSIDE LIGHTS SWITCH TO DISPLAY FLASHING RED AND INTERLOCK IL1-IL2 CLOSES. PART # 625-203, NOTE 4

NOTE:

For 24V incoming power consult factory.

NOTE:

Power to control panel must be from fused disconnect supplied by others. All electrical work must meet all applicable codes. All devices shown in de-energized state.

OPERATION INSTRUCTIONS — ALS2

Simplified Instructions

ALS2 (SERCO P/N 6014245; KELLEY P/N 6014244) Fig. 12

1. Restrain vehicle (with vehicle restraint or manual wheel chocks).

▲ WARNING

Before loading or unloading make certain that the vehicle wheels are chocked or a vehicle restraining device holds the vehicle in place.

2. Open dock door.
 - If interlocked to a door opened switch and leveler stored switch the inside light will remain solid Red and the outside light will change to flashing Red as the door starts to open.
 - If interlocked to a door closed switch the outside light will change to flashing Red, and when the door is fully opened, the inside light will change to solid Green.

Dock leveler motor is enabled (the leveler interlock terminals 15-16 now close).

3. Put dock leveler into vehicle.
 - If interlocked to a door opened switch and leveler stored switch the inside light will change to solid Green.

4. Load/Unload vehicle

5. Store dock leveler.

- If interlocked to a door opened switch and leveler stored switch the inside light will change to solid Red when the leveler is returned to its stored position.

6. Close Door.

- If interlocked to a door opened switch and leveler stored switch the outside light will change to flashing Green when the door is not fully opened.
- If interlocked to a door closed switch when the door fully closes the outside light will change to flashing Green.
- Dock leveler motor is disabled (the leveler interlock terminals 15-16 now open).

7. Release manual vehicle restraint or remove manual wheel chocks.

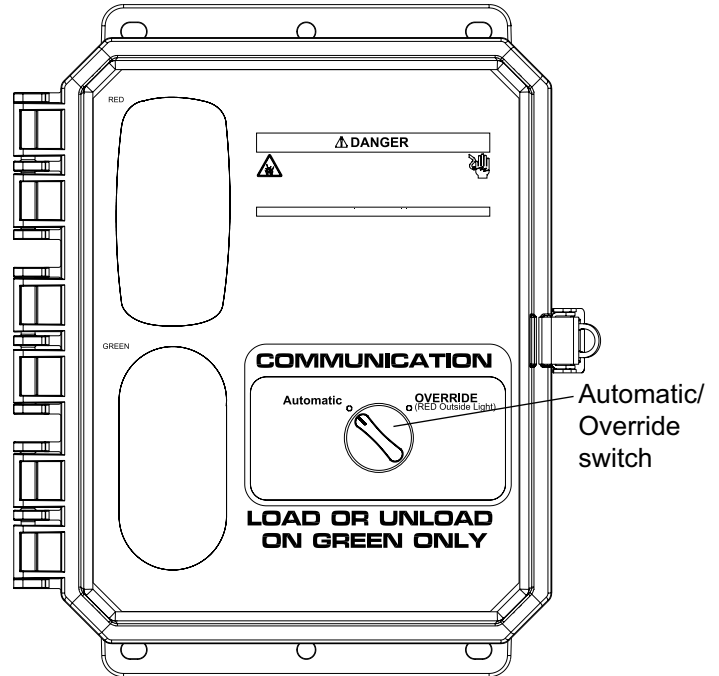

NOTE:

The selector switch "Override/(Red Outside Light)" position is only used to force the exterior lights Red when the Leveler is stored and/or when the door is closed. This is used as a signal to outside of the Dock that it is closed and not ready to accept vehicles or to restrain vehicles. The selector switch will not illuminate the interior Green light.

The interior Green light will only be on; when the Leveler is positioned outside of the lip keepers, (either on the vehicle or in the end loading position) AND the door is open.

When the inside light is Green the panels second set of auxiliary contacts are closed.

OPERATION INSTRUCTIONS — ALS2, continued

Detailed Instructions

ALS2 (SERCO P/N 6014245; KELLEY P/N 6014244) Fig. 13

NOTE:

This control panel has only two approved control options. Any other installation or operation of this equipment must be reviewed and approved by the manufacturer.

INTRODUCTION

Two separate limit switches are connected to the system. LS2 switches the outside lights and closes the leveler interlock terminals 15-16 (LED-O1, the terminals are located on the terminal strip on the backplate). LS1 switches the inside lights and closes the auxiliary terminals IL1-IL2 (LED- IL, the terminals are located on the circuit board). When LS1 is open the selector switch can be manually turned to force the outside lights to red but the inside lights will remain Red and the leveler interlock terminals 15-16 will remain open unless LS2 is closed.

OPTION 1

LS2 = Door Opened Switch (625-208) - When the dock door is opened LS2 closes and the inside lights continue to display solid Red, the outside lights switch to display flashing Red and the Leveler Interlock terminals 15-16 close.

LS1 = Leveler stored limit switch (625-203) and bracket (5862417) for Serco units or lip switch kit (908877) for Kelley units, each sold separately – When the leveler is removed from the stored position LS1 opens and the inside lights switch to display solid Green, the outside lights continue to display flashing Red and the Auxiliary terminals IL1-IL2 close.

1. Restrain vehicle (with vehicle restraint or wheel chocks).

⚠ WARNING

Before loading or unloading make certain that the vehicle wheels are chocked or a vehicle restraining device holds the vehicle in place.

2. Raise/Open Door

•When the door is fully opened LS2 closes and the LEDs for I4 and O1 illuminate.

- The inside light will remain solid Red and the outside light will change to flashing RED.
- The Leveler Interlock terminals 15-16 close. If they are interconnected to a Dock Leveler controller, dock leveler and leveler control circuit is now enabled.

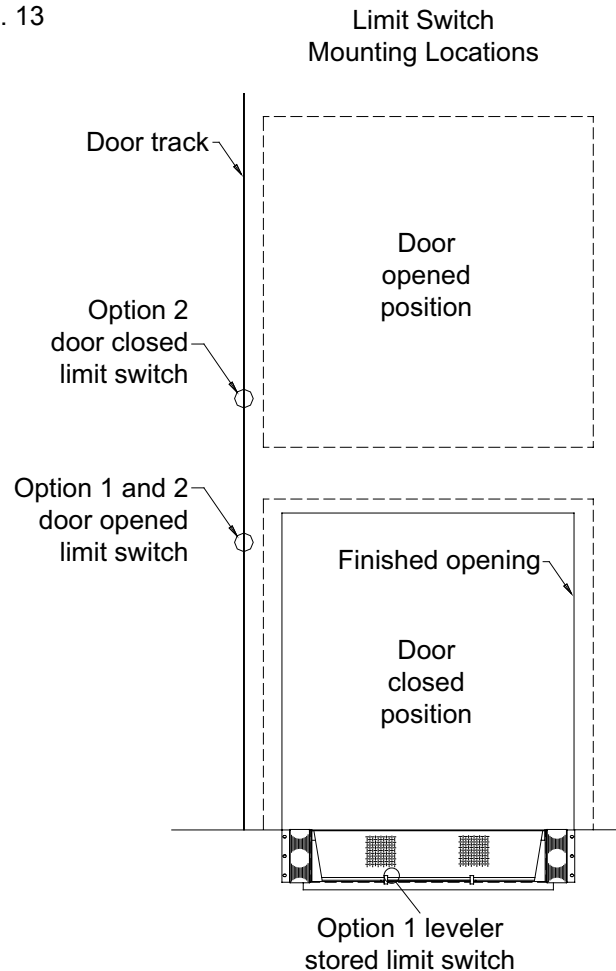
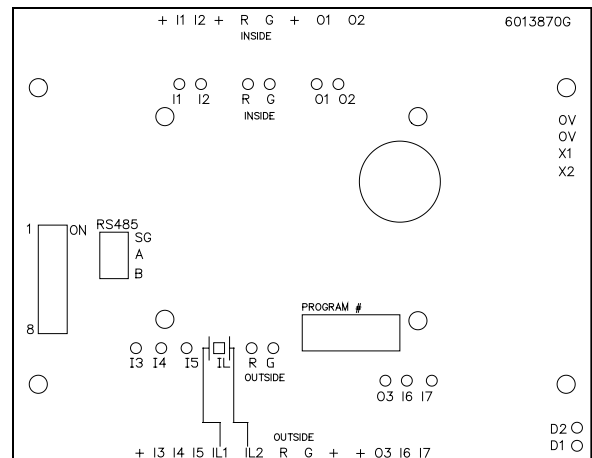

Fig. 14



OPERATION INSTRUCTIONS — ALS2, continued

Detailed Instructions

3. Position Dock Leveler into vehicle.

- When the leveler lip is positioned outside the lip keepers. (i.e. outside the storage position) LS1 closes and the LEDs for I3 and IL illuminate.
- The inside light will change to solid Green and the outside light will remain flashing RED .
- Auxiliary terminals IL1-IL2 are now closed.

4. Load/Unload vehicle.

5. Restore dock Leveler to the stored position.

- When the leveler lip is positioned into the lip locks. (i.e. in the storage position) LS1 opens and the LED for I3 extinguish and the LED for IL illuminates.
- The inside light will change to solid Red and the outside light will continue to flash Red.
- Auxiliary terminals IL1-IL2 are now open.

6. Lower/Close Door.

- When the door is no longer fully opened LS2 opens and the LEDs for I4 and O1 extinguish.
- The inside light will stay solid Red and the outside light will change to flashing Green.
- If the Leveler Interlock terminals 15-16 are interconnected to a Dock Leveler controller, dock leveler and leveler control circuit is now disabled.

7. Release manual vehicle restraint or remove manual wheel chocks.

OPTION 2

LS2 = Door Closed Switch (625-208) – LS2 closes when the dock door is not closed, inside lights continue to display solid Red, the outside lights switch to display flashing Red and the Interlock terminals 15-16 close.

LS1 = Door Open Switch (625-208) – LS1 closes when the dock door is fully opened, the inside lights change to display solid Green, the outside lights continue to flash Red and the Auxiliary terminals IL1-IL2 close.

Fig. 15

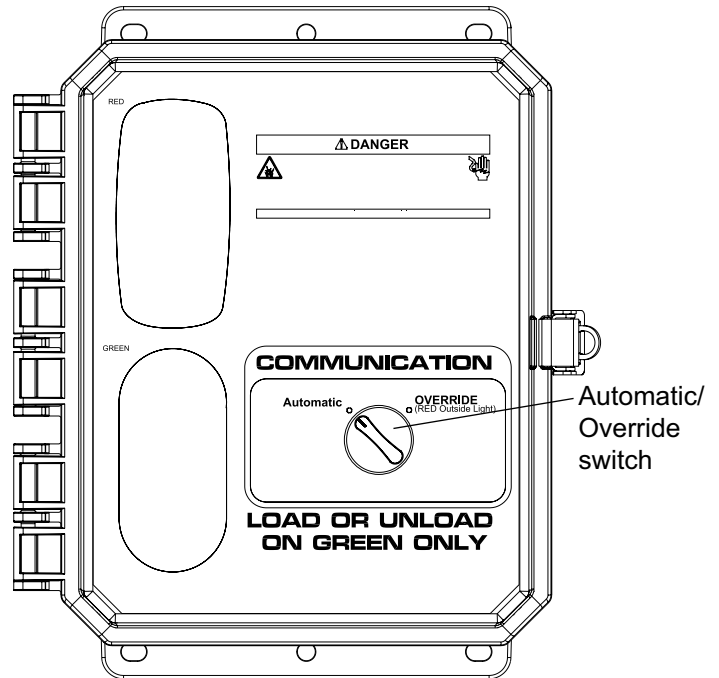

NOTE:

The selector switch “Override/(Red Outside Light)” position is only used to force the exterior lights Red when the Leveler is stored and/or when the door is closed. This is used as a signal to outside of the Dock that it is closed and not ready to accept vehicles or to restrain vehicles. The selector switch has no effect upon the interior Green Light. With option 1, the interior Green light will only be on; when the Leveler is positioned outside of the lip keepers, (either on the vehicle or in the end loading position) AND the door is open. With option 2, the interior Green light will only be on when the door is fully opened. When the inside light is Green the panels second set of auxiliary contacts are closed.

OPERATION INSTRUCTIONS — ALS2, continued

Detailed Instructions

1. Restrain vehicle (with vehicle restraint or wheel chocks).

▲ WARNING

Before loading or unloading make certain that the vehicle wheels are chocked or a vehicle restraining device holds the vehicle in place.

2. Raise/Open Door

- As the door starts to open LS2 closes and the LEDs for I4 and O1 illuminate.
- The inside light will remain solid Red and the outside light change to flashing RED.
- Interlock terminals 15-16 close.
- When the door is fully opened LS1 closes and the LEDs for I3 and IL illuminate.
- The inside light will change to solid Green and the outside light will remain flashing RED.
- The auxiliary terminals IL1-IL2 are now closed.

3. Position Dock Leveler into vehicle.

4. Load/Unload vehicle.

5. Restore dock Leveler to the stored position.

6. Lower/Close Door.

- As the door starts to close LS1 opens and the LEDs for I3 and IL extinguish.
- The inside light will change to solid Red and the outside light will continue to flash Red.
- The Auxiliary terminals IL1-IL2 are now open.

OPERATION INSTRUCTIONS — ALS2, continued

Detailed Instructions

7. Lower/Close Door.

- As the door completely closes, LS2 opens and the LEDs for I4 and O1 extinguish.
- The inside light will remain solid Red and the outside light changes to flashing Green.
- Interlock terminals 15-16 open when LS2 opens.

8. Release manual vehicle restraint or remove manual wheel chocks.

ALS2 LOGIC CHART

OPTION 1: ALS2-LS1 DIP1 = ON

Inputs		Outputs						
Selector Switch (I1)	LS1 (I3)	LS2 (I4)	Inside Red	Inside Green	Auxiliary I11 & I12	Outside Red	Outside Green	Interlock 15 & 16
Automatic(off)	Closed(on)	Open(off)	X				F	
Automatic(off)	Open(off)	Open(off)		X	X	F		
Automatic(off)	Closed(on)	Closed(on)	X			F		X
Automatic(off)	Open(off)	Closed(on)		X	X	F		X
Override(on)	Closed(on)	Open(off)	X			F		
Override(on)	Open(off)	Open(off)		X	X	F		
Override(on)	Closed(on)	Closed(on)	X			F		X
Override(on)	Open(off)	Closed(on)		X	X	F		X

OPTION 2: ALS2-LS1 DIP1 = OFF

Inputs		Outputs						
Selector Switch (I1)	LS1 (I3)	LS2 (I4)	Inside Red	Inside Green	Auxiliary I11 & I12	Outside Red	Outside Green	Interlock 15 & 16
Automatic(off)	Open(off)	Open(off)	X				F	
Automatic(off)	Closed(on)	Open(off)		X	X	F		
Automatic(off)	Open(off)	Closed(on)	X			F		X
Automatic(off)	Closed(on)	Closed(on)		X	X	F		X
Override(on)	Open(off)	Open(off)	X			F		
Override(on)	Closed(on)	Open(off)		X	X	F		
Override(on)	Open(off)	Closed(on)	X			F		X
Override(on)	Closed(on)	Closed(on)		X	X	F		X

Logic Chart Legend: X = ON F= Flashing

IR = Inside Red light / IG= Inside Green Light / OR= Outside Red light / OG= Outside Green Light
 Auxiliary Terminals IL1-IL2. / Leveler Interlock Terminals 15 to 16

Option 1: LS1 = Leveler Stored Limit Switch (Serco p/n 625-203 or Kelley p/n 908-877) ON when leveler is stored.
 LS2 = Door opened Limit Switch (625-208) ON when door is opened.

Option 2: LS1 = Door opened Limit Switch (625-208) ON when door is opened.
 LS2 = Door closed Limit Switch (625-208) ON when door is not closed.

WIRING DIAGRAM — ALS2

ALS2 (SERCO P/N 6014245; KELLEY P/N 6014244)

Fig. 16

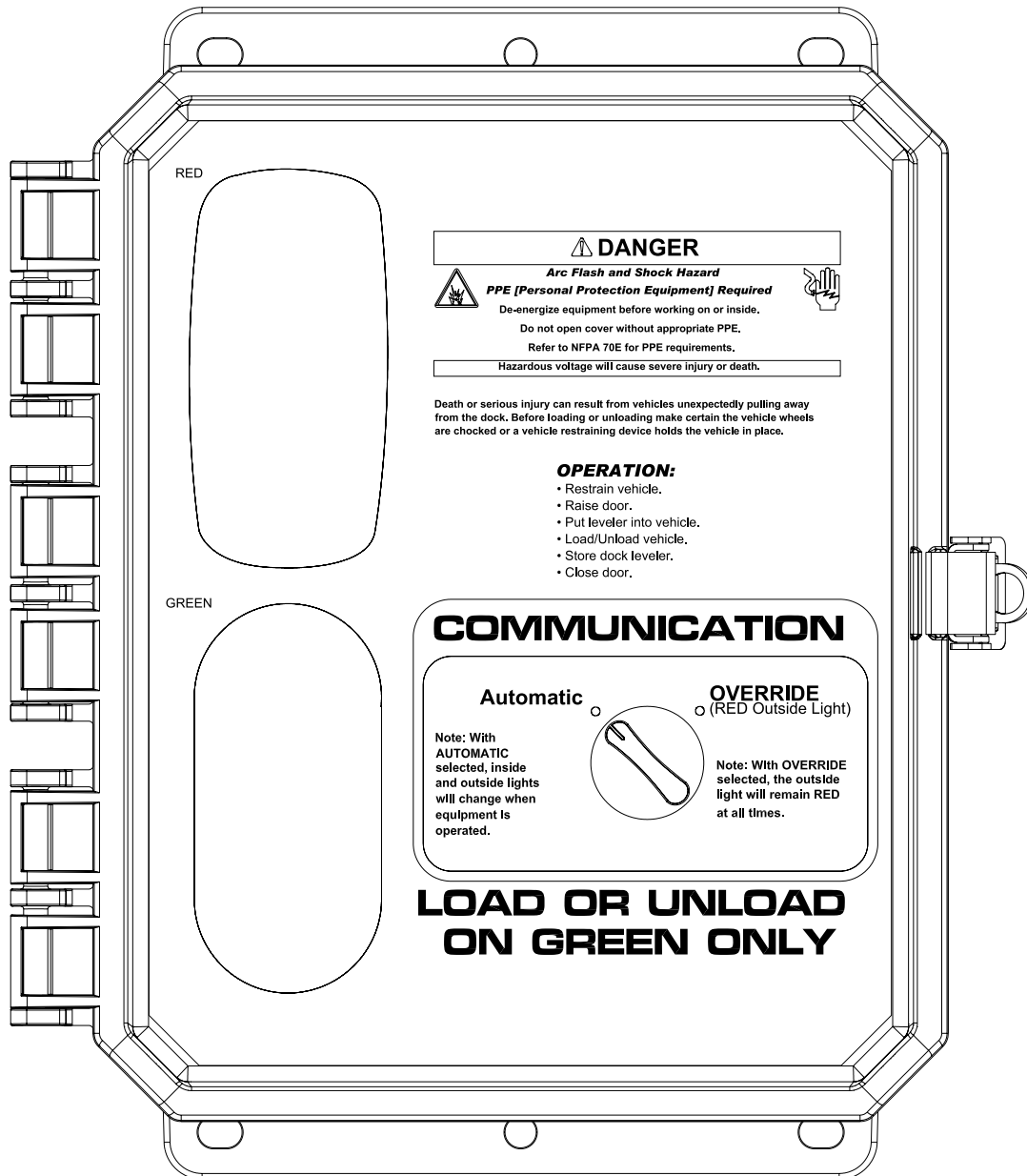

WIRING DIAGRAM — ALS2, continued

ALS2 (SERCO P/N 6014245; KELLEY P/N 6014244)

Fig. 17

120V/1PH/60HZ

CB/FU TO BE SUPPLIED BY OTHERS
 SUPPLY BCPD = CB/FU 15AMP MAX
 PANEL FLA = 0.4AMPS
 SCCR = 5KA

NOTES:

1. FIELD TERMINAL WIRING: 90 DEGREE WIRE, MIN 16AWG FOR SIGNAL WIRING, MIN 14AWG FOR INCOMING POWER, SEE CHART IN PANEL FOR TORQUE REQUIREMENTS
2. INTERLOCK 1: TERMINALS IL1-IL2, DRY CONTACT RATED 1/2A@24VDC MAX. EXTERNAL FUSE REQUIRED.
3. IF A 3 WIRE DC SWITCH IS USED CONNECT 0V FROM THE SWITCH TO THIS TERMINAL
4. LEVELER INTERLOCK: TERMINALS 15-16, DRY CONTACT RATED 2A @ 120V MAX. EXTERNAL FUSE REQUIRED. CLOSSES WHEN LS2 IS CLOSED.

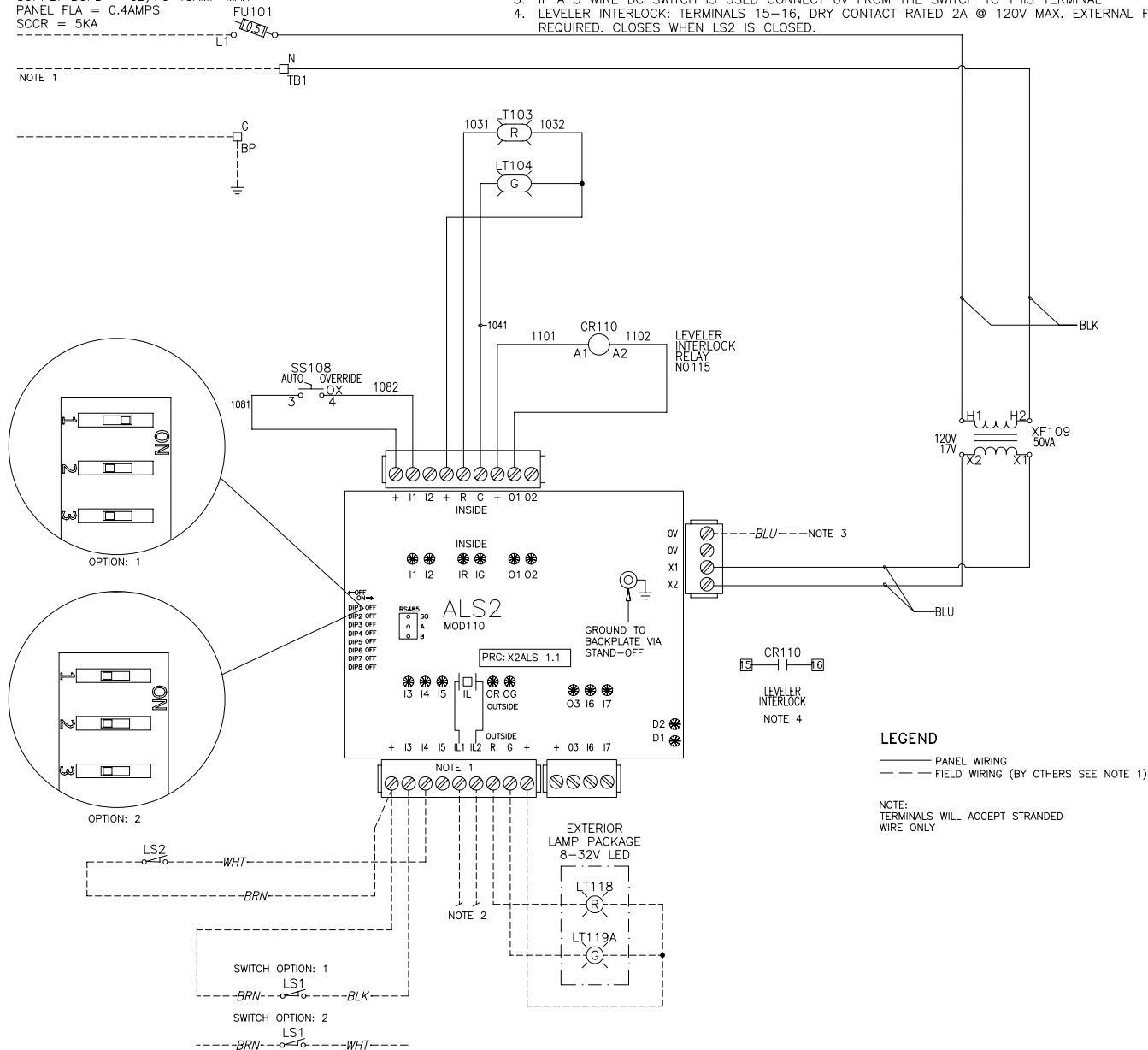

LEGEND

- PANEL WIRING
- - - FIELD WIRING (BY OTHERS SEE NOTE 1)

NOTE:
 TERMINALS WILL ACCEPT STRANDED WIRE ONLY

SWITCH OPTIONS

- 1) DOOR OPEN SWITCH LS2: SWITCHES OUTSIDE LIGHTS AND ENABLES LEVELER INTERLOCK 15-16. 14 ON WHEN DOOR IS FULLY OPEN. PART # 625208
- 2) DOOR CLOSED SWITCH LS2: SWITCHES OUTSIDE LIGHTS AND ENABLES LEVELER INTERLOCK 15-16. 14 IS ON WHEN DOOR IS NOT CLOSED. PART # 625208
- DOOR OPENED SWITCH LS1: SWITCHES INSIDE LIGHTS AND ENABLES AUX. INTERLOCK IL1-IL2. 13 ON WHEN DOOR IS FULLY OPENED. PART # 625208

NOTE:

For 24V incoming power consult factory.

NOTE:

Power to control panel must be from fused disconnect supplied by others. All electrical work must meet all applicable codes. All devices shown in de-energized state.

OPERATION INSTRUCTIONS — AMLS

Simplified Instructions

AMLS (SERCO P/N 6014247; KELLEY P/N 6014246) Fig. 18

1. Restrain vehicle (with vehicle restraint or wheel chocks).

⚠ WARNING

Before loading or unloading make certain that the vehicle wheels are chocked or a vehicle restraining device holds the vehicle in place.

2. Raise door.

- The inside light will remain solid Red and the outside light will change to flashing Red when the door is opened.
- Dock leveler motor is enabled.

3. Put dock leveler into vehicle.

⚠ WARNING

Do not switch to "Enter Vehicle" unless wheels have been chocked or a vehicle restraining device holds the vehicle in place.

4. Turn selector switch to the "Enter Vehicle" position.

- The inside light will change to solid Green.

5. Load/Unload vehicle.

6. Store dock leveler.

7. Close door.

8. Turn selector switch to the "Do Not Enter Vehicle" position.

- The inside light will change to solid red and the outside light will change to flashing Green.

9. Release manual vehicle restraint or remove manual wheel chocks.

NOTE:

The selector switch "Enter Vehicle" position can be used to force the exterior lights Red when the door is closed. This is used as a signal to outside of the Dock that it is closed and not ready to accept Vehicles.

Only when the door is opened is the dock leveler motor enabled. Turning the selector switch to the "Enter Vehicle" position does not enable the dock leveler.

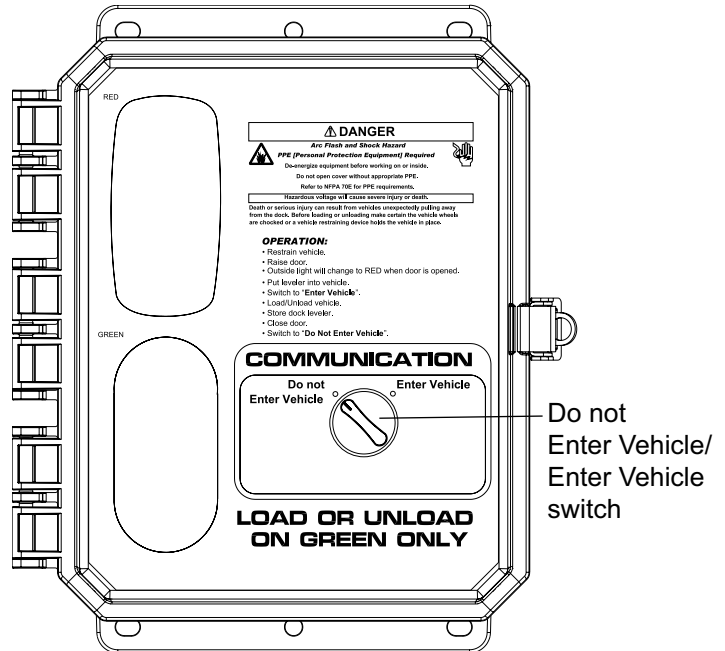

OPERATION INSTRUCTIONS — AMLS, continued

Detailed Instructions

NOTE:

This control panel has only one approved control option. Any other installation or operation of this equipment must be reviewed and approved by the manufacturer.

INTRODUCTION

A single limit switch changes the outside light and enables a set of interlock contacts. Once the operator places the dock leveler into the trailer the selector switch (SS), is manually turned to the load truck position, changing the inside lights to green.

LIMIT SWITCH

LS1 = Door Opened Switch (625-208) - When the dock door is fully opened, LS1 opens and the inside lights remain solid Red, the outside lights change to display flashing Red and the Interlock terminals IL1-IL2 close.

1. Restrain vehicle (with vehicle restraint or wheel chocks).

▲ WARNING

Before loading or unloading make certain that the vehicle wheels are chocked or a vehicle restraining device holds the vehicle in place.

2. Raise/Open Door

- When the door is fully opened, LS1 opens and the LED for I3 extinguish and the LED for IL illuminates.
- The inside light remains solid Red and the outside light changes to flashing RED.
- If the Interlock terminals IL1-IL2 are interconnected to a Dock Leveler controller, dock leveler and leveler control circuit is now enabled.

3. Position Dock Leveler into vehicle.

4. Turn Selector Switch "SS" to the "Enter Vehicle" position.

- The "I1" LED goes on.
- The inside light changes to Solid Green and the outside light remains flashing RED.

5. Load/Unload vehicle.

Fig. 19

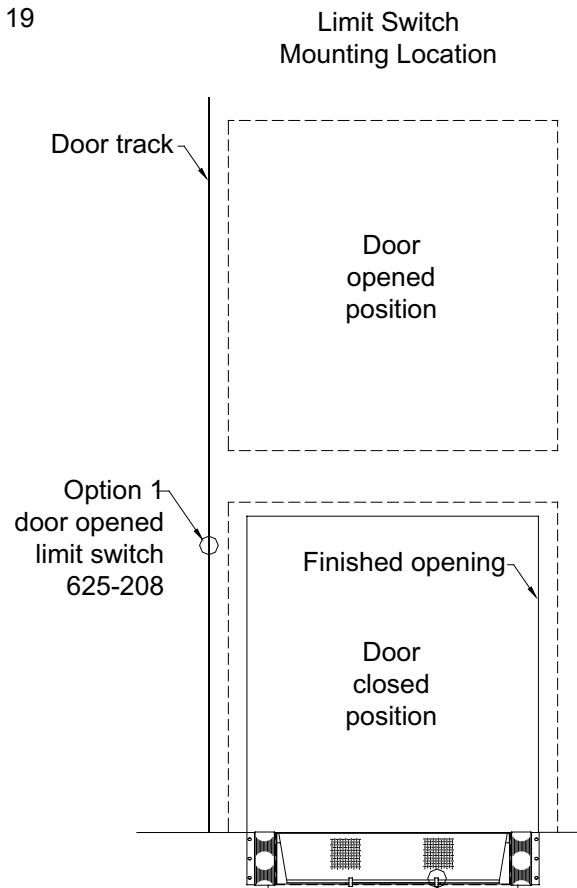
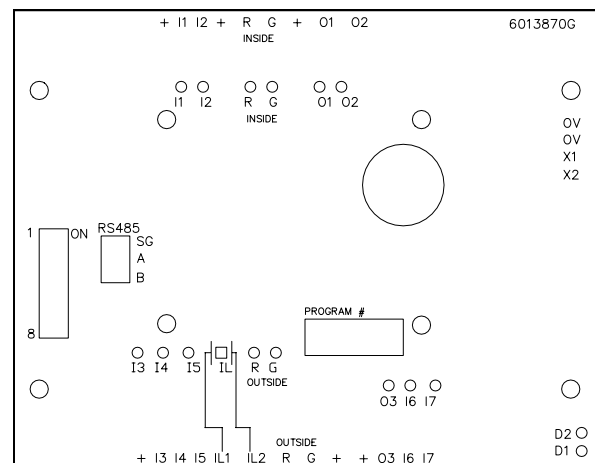

Fig. 20



OPERATION INSTRUCTIONS — AMLS, continued

Detailed Instructions

6. Restore dock Leveler to the stored position.
7. Lower/Close Door.
 - When the door is not fully opened, LS1 closes, the LED for I3 illuminates and the LED for IL extinguish.
 - If the Interlock terminals IL1-IL2 are interconnected to a Dock Leveler controller, dock leveler and leveler control circuit is now disabled.
8. Turn Selector Switch “SS” to the “Do Not Enter Vehicle” position.
 - The “I1” LED goes off.
 - The inside light will change to solid Red and the outside light will change to flashing Green.
9. Release manual vehicle restraint or remove manual wheel chocks.

AMLS LOGIC CHART

Inputs		Outputs				
Selector Switch (I1)	LS1 (I3)	Inside Red	Inside Green	Interlock	Outside Red	Outside Green
Do not enter(off)	Open(off)	X		X	F	
Do not enter(off)	Closed(on)	X				F
Enter(on)	Open(off)		X	X	F	
Enter(on)	Closed(on)		X		F	

LS1 = Door opened Limit Switch (625-208) OFF when door is opened

Logic Chart Legend: X = ON F= Flashing

WIRING DIAGRAM — AMLS

AMLS (SERCO P/N 6014247; KELLEY P/N 6014246)

Fig. 21

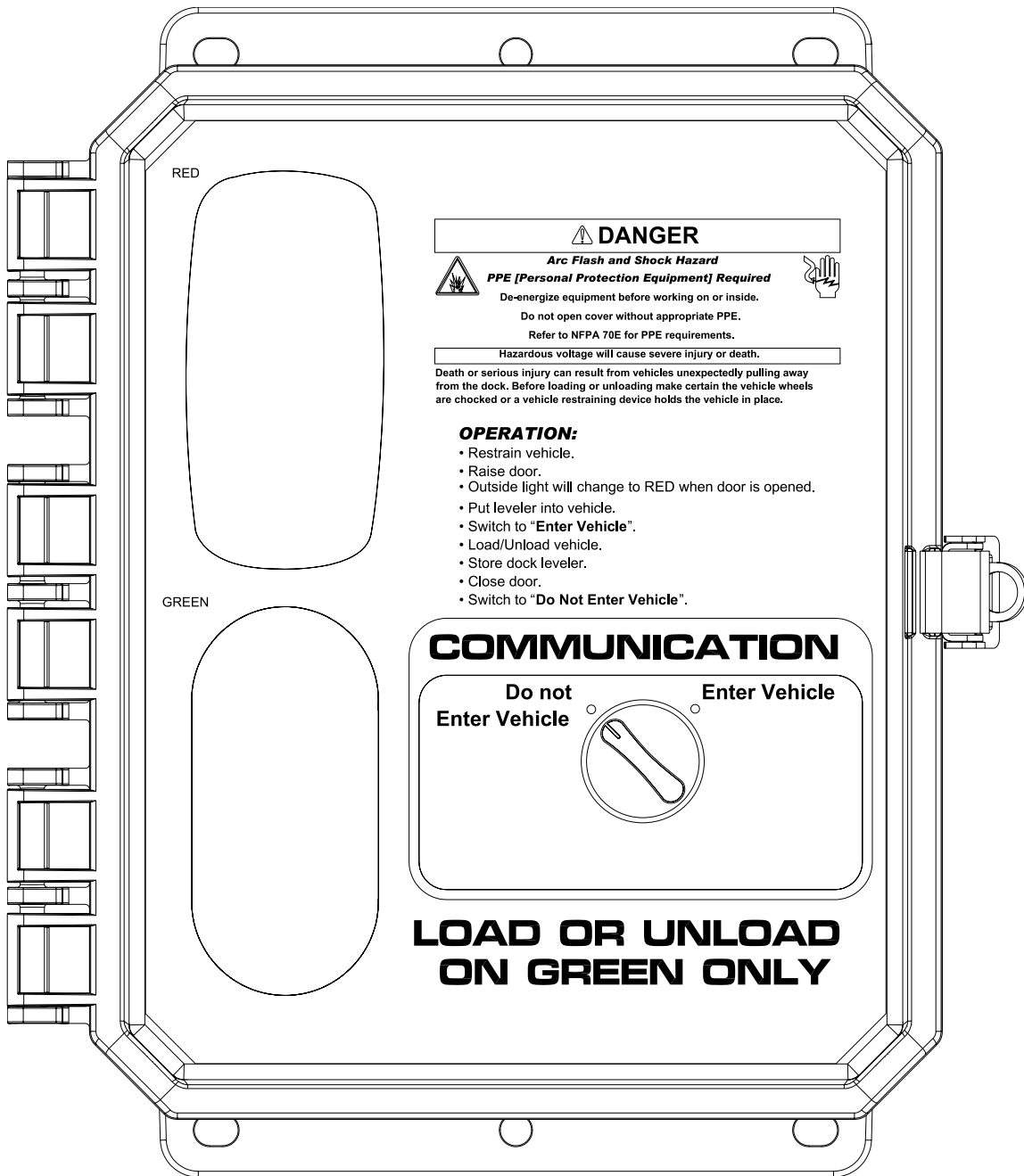

WIRING DIAGRAM — AMLS, continued

AMLS (SERCO P/N 6014247; KELLEY P/N 6014246)

Fig. 22

120V/1PH/60HZ

CB/FU TO BE SUPPLIED BY OTHERS
 SUPPLY BCPD = CB/FU 15AMP MAX
 PANEL FLA = 0.4AMPS
 SCCR = 5KA

NOTES

1. FIELD TERMINAL WIRING: 90 DEGREE WIRE, MIN 16AWG FOR SIGNAL WIRING, MIN 14AWG FOR INCOMING POWER, SEE CHART IN PANEL FOR TORQUE REQUIREMENTS
2. INTERLOCK 1: TERMINALS IL1-IL2, DRY CONTACT RATED 1/2A @ 24VDC MAX. EXTERNAL FUSE REQUIRED.
3. IF A 3 WIRE DC SWITCH IS USED CONNECT 0V FROM THE SWITCH TO THIS TERMINAL

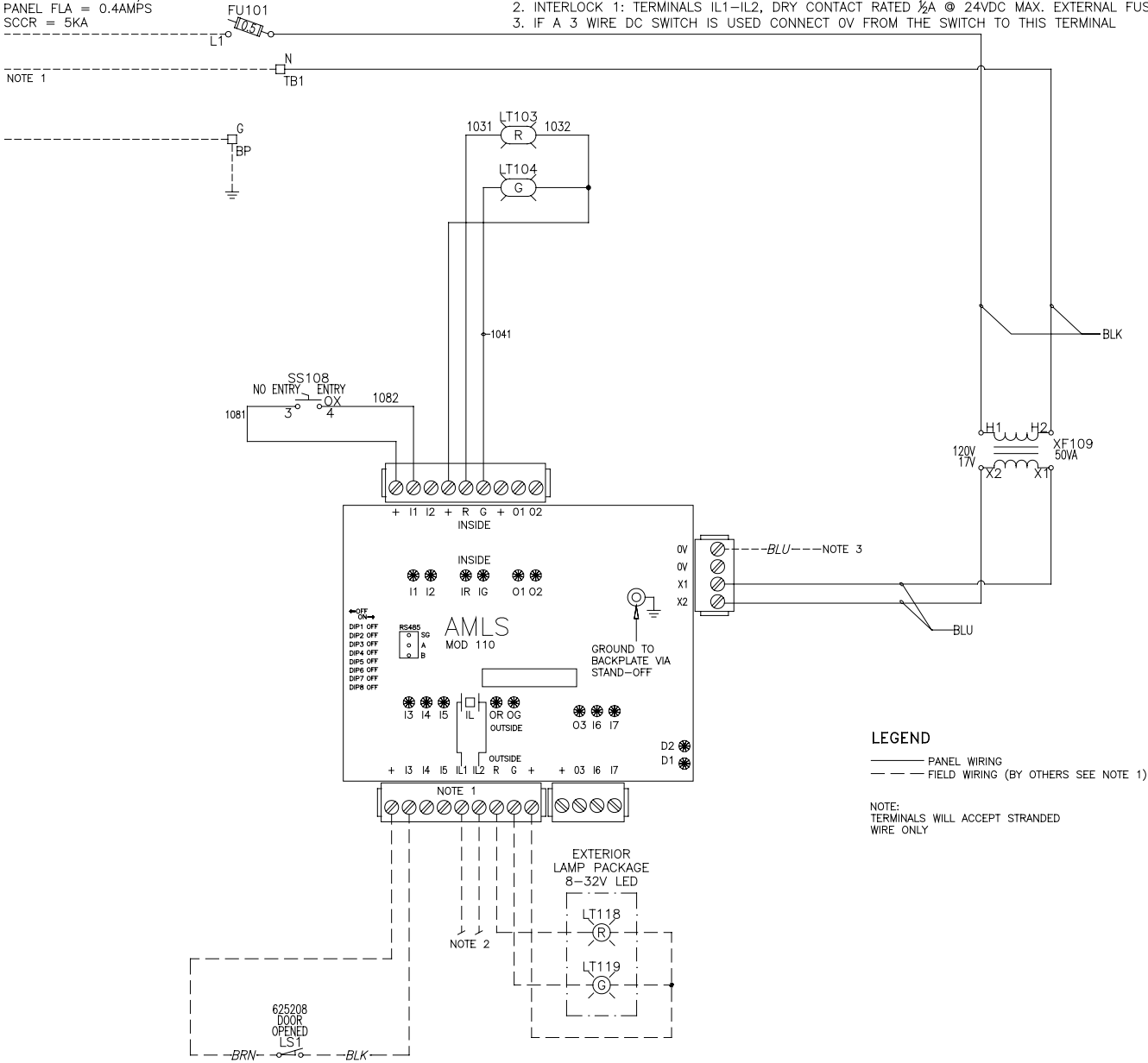

LEGEND

- PANEL WIRING
- - - FIELD WIRING (BY OTHERS SEE NOTE 1)

NOTE:
 TERMINALS WILL ACCEPT STRANDED
 WIRE ONLY

NOTE:

For 24V incoming power consult factory.

NOTE:

Power to control panel must be from fused disconnect supplied by others. All electrical work must meet all applicable codes. All devices shown in de-energized state.

OPERATION INSTRUCTIONS — MLS

Simplified Instructions

MLS (SERCO P/N 6014249; KELLEY P/N 6014248) Fig. 23

1. Restrain Vehicle (with vehicle restraint or manual wheel chocks).

⚠ WARNING

Before loading or unloading make certain that the vehicle wheels are chocked or a vehicle restraining device holds the vehicle in place.

Do not switch to "Enter Vehicle" unless wheels have been chocked or a vehicle restraining device holds the vehicle in place.

2. Turn selector switch to the "Enter Vehicle" position.
 - Inside light will change to solid Green.
 - Outside light will change to flashing Red.
 - Aux. interlock contacts close.
3. Put leveler into vehicle.
4. Load/Unload Vehicle.
5. Store dock leveler.
6. Turn selector switch to the "Do Not Enter Vehicle" position.
 - Inside light will change to solid Red.
 - Outside light will change to flashing Green.
 - Dock leveler motor is now disabled.
7. Release manual vehicle restraint or remove manual wheel chocks.

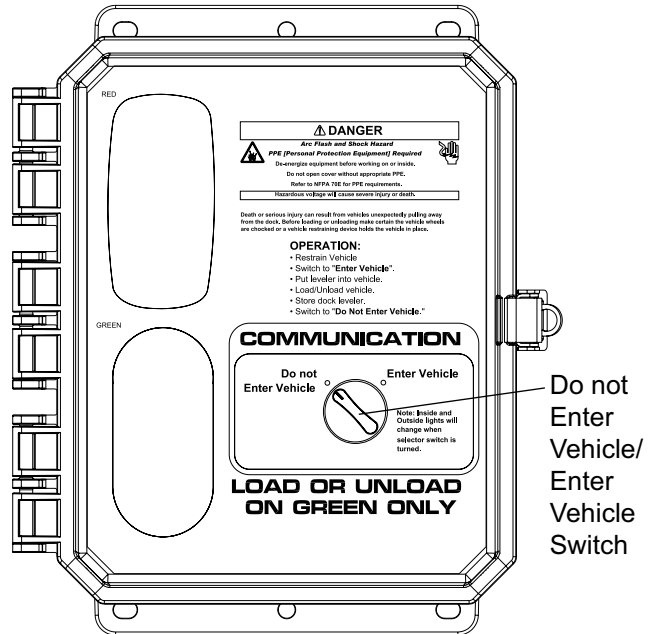

OPERATION INSTRUCTIONS — MLS, continued

Detailed Instructions

MLS (SERCO P/N 6014249; KELLEY P/N 6014248)

Fig. 24

NOTE:

This control panel has only one approved control option. Any other installation or operation of this equipment must be reviewed and approved by the manufacturer.

INTRODUCTION

There are no limit switches. When the panel face mounted selector switch is in the “Do Not Enter Vehicle” position the outside lights display flashing Green and the inside lights display red. When the operator turns the selector switch to the “Enter Vehicle” position the outside lights change to display flashing Red and the inside lights display Green. The Interlock contacts are closed when the selector switch is in the “Enter Vehicle” position.

1. Restrain vehicle (with vehicle restraint or wheel chocks).

⚠ WARNING

Before loading or unloading make certain that the vehicle wheels are chocked or a vehicle restraining device holds the vehicle in place.

2. Turn Selector Switch “SS” to the “Enter Vehicle” position.

- The “I1” LED goes on.
- The inside light changes to Solid Green and the outside light change to flashing RED.
- If the Interlock terminals IL1-IL2 are interconnected to a Dock Leveler controller, dock leveler and leveler control circuit is now enabled.

3. Position Dock Leveler into vehicle.

4. Load/Unload vehicle.

5. Restore dock Leveler to the stored position.

6. Turn Selector Switch “SS” to the “Do Not Enter Vehicle” position.

- The “I1” LED goes off.
- The inside light will change to solid Red and the outside light will change to flashing Green.
- If the Interlock terminals IL1-IL2 are interconnected to a Dock Leveler controller, dock leveler and leveler control circuit is now disabled.

7. Release manual vehicle restraint or remove manual wheel chocks.

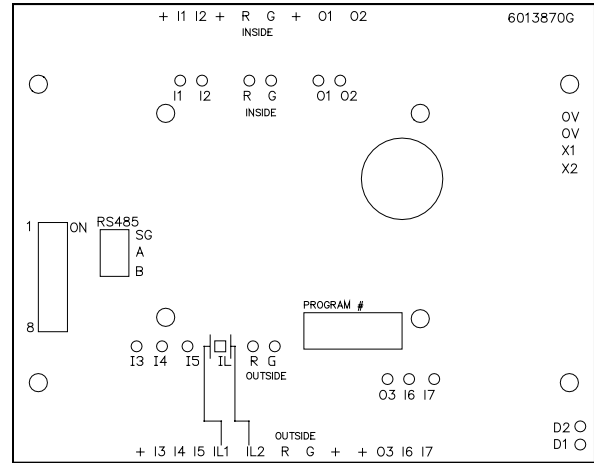

MLS LOGIC CHART

Inputs	Outputs				
	Inside red	Inside Green	Interlock	Outside Red	Outside Green
Selector Switch (I1)					
Do not enter (off)	X				F
Enter (on)		X	X	F	

Logic Chart Legend: X = ON F= Flashing

WIRING DIAGRAM — MLS

MLS (SERCO P/N 6014249; KELLEY P/N 6014248)

Fig. 25

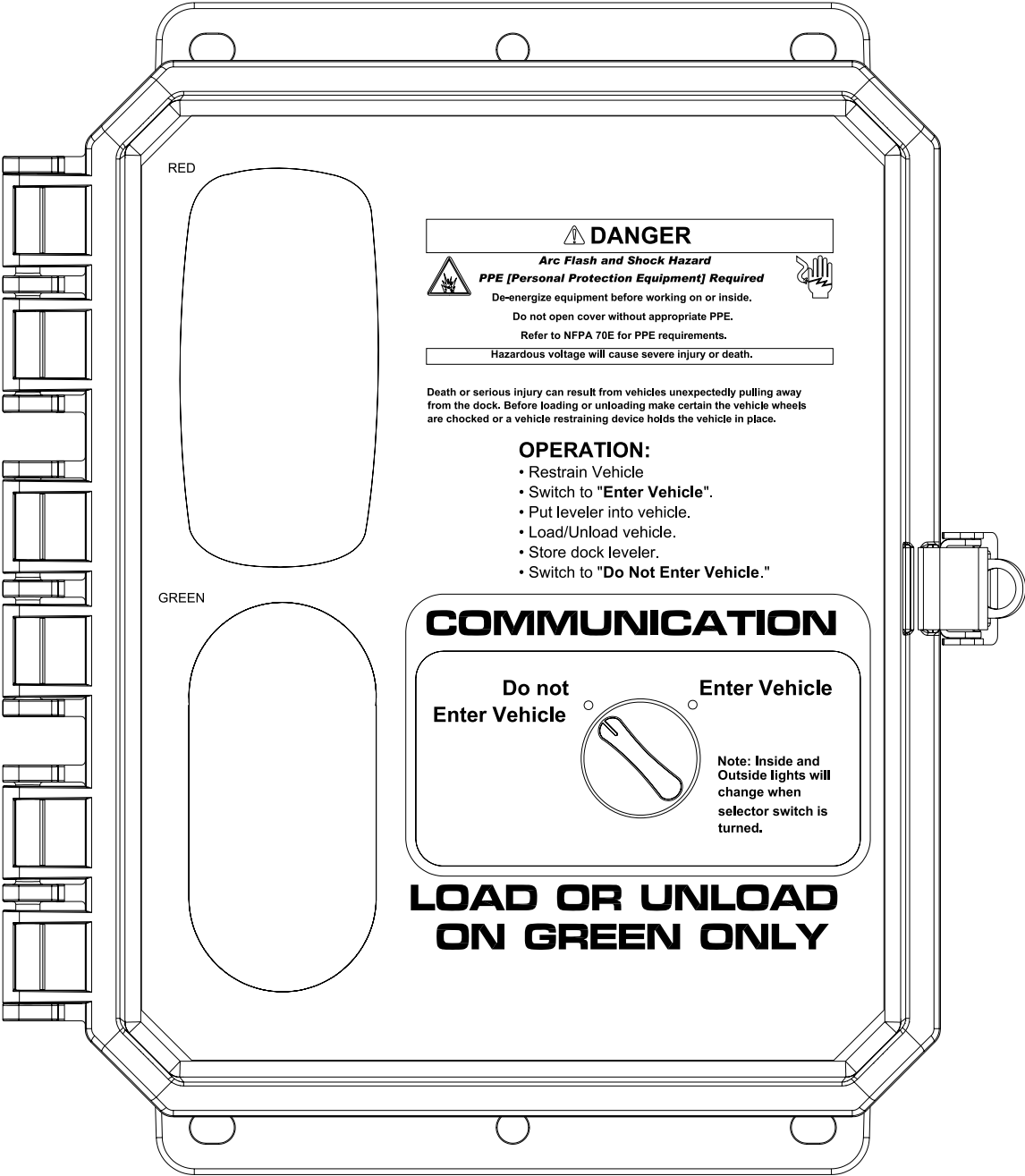

WIRING DIAGRAM — MLS, continued

MLS (SERCO P/N 6014249; KELLEY P/N 6014248)

Fig. 26

120V/1PH/60HZ

INCOMING SERVICE TO BE TERMINATED AT DISCONNECT
 CB/FU TO BE SUPPLIED BY OTHERS
 SUPPLY BCPD=CB/FU 15AMP MAX
 PANEL FLA = 0.4AMPS
 SCCR = 5KA

NOTES

1. FIELD TERMINAL WIRING: 90 DEGREE WIRE, MIN 16AWG FOR SIGNAL WIRING, MIN 14AWG FOR INCOMING POWER, SEE CHART IN PANEL FOR TORQUE REQUIREMENTS
2. INTERLOCK 1: TERMINALS IL1-IL2, DRY CONTACT RATED ½A@24VDC MAX. EXTERNAL FUSE REQUIRED.

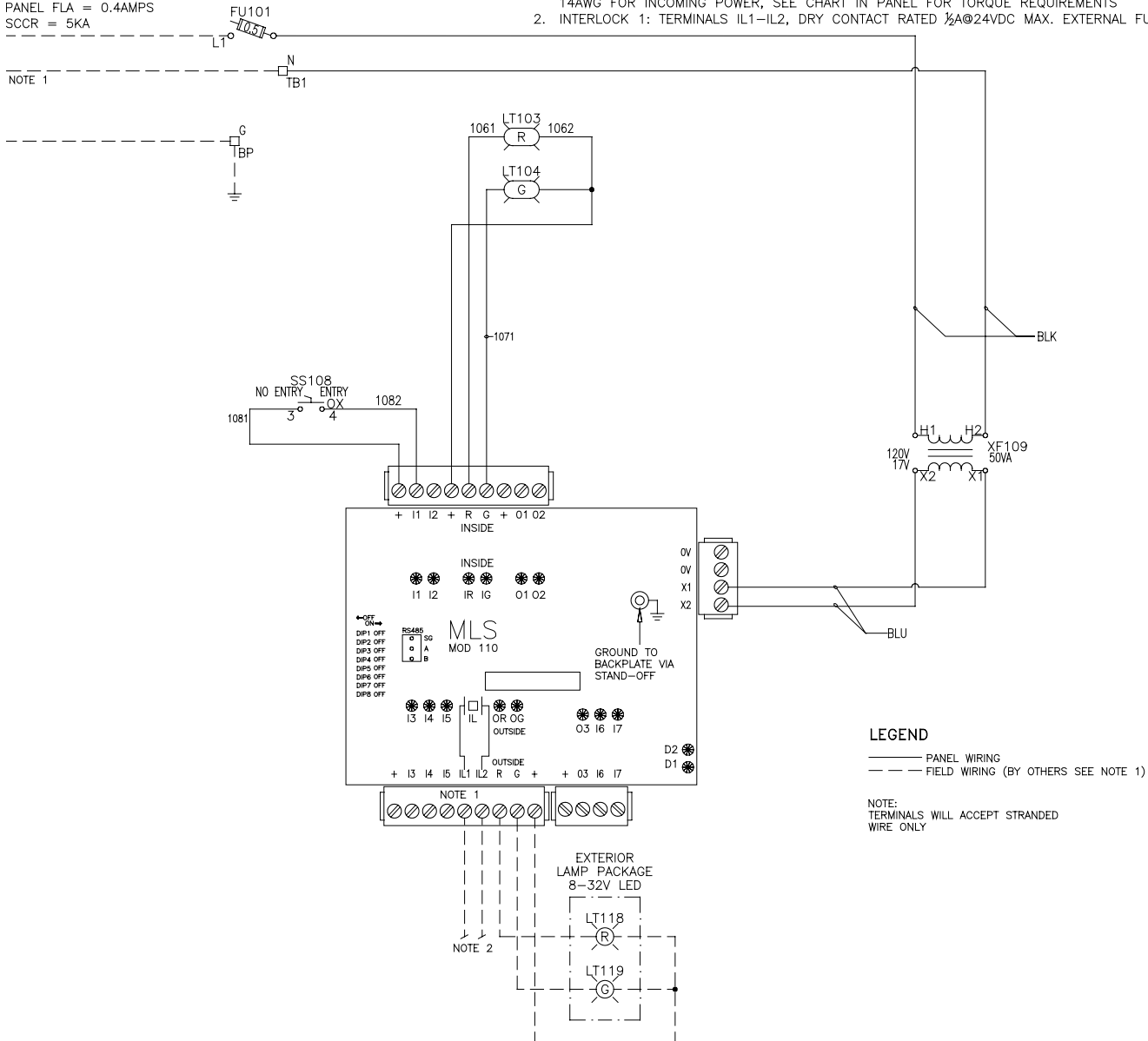

NOTE:

For 24V incoming power consult factory.

NOTE:

Power to control panel must be from fused disconnect supplied by others. All electrical work must meet all applicable codes. All devices shown in de-energized state.

PARTS LIST

⚠ WARNING

To ensure proper function, durability and safety of the product, only replacement parts that do not interfere with the safe, normal operation of the product must be used. Incorporation of replacement parts or modifications that weaken the structural integrity of the product, or in any way alter the product from its normal working condition at the time of purchase from 4Front Engineered Solutions, Inc. may result in product malfunction, breakdown, premature wear, death or serious injury.

Fig. 27

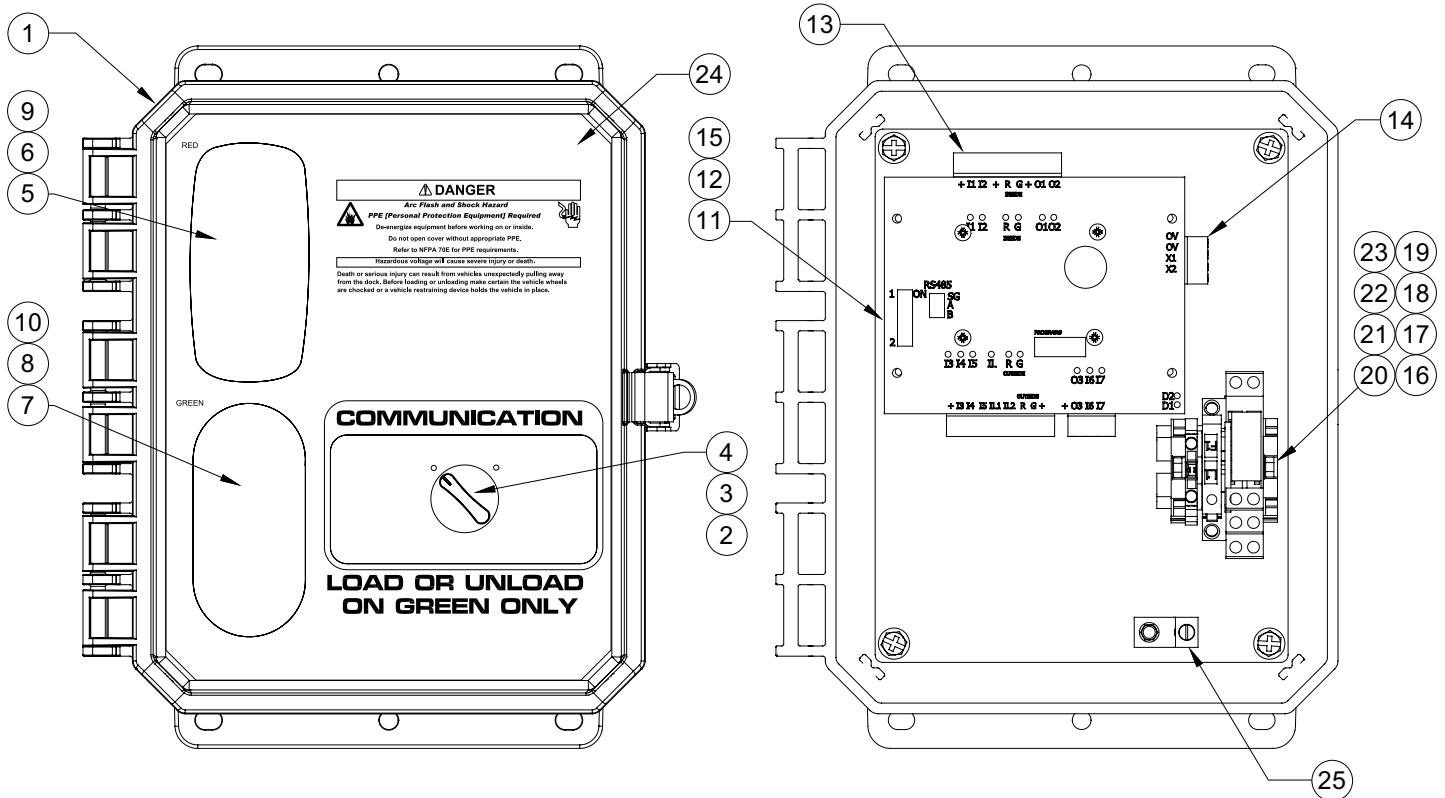

PARTS LIST, continued

Item	Quantity	Description	Part Number
1	1	CONTROL PANEL ENCLOSURE 10"X8"X6" NEMA12	6012916
2	1	SELECTOR SWITCH-2 POS. MAINT.	6012565
3	1	CONTACT BLOCK SWITCH N.O.	6012563
4	1	MOUNTING COLLAR	6012562
5	1	RED LENS	823100
6	1	LIGHT BASE RED	823107
7	1	GREEN LENS	AP0027
8	1	LIGHT BASE GREEN	823111
9	2	LRU, RED, CURRENT REGULATED	6006375
10	2	LRU, GREEN, CURRENT REGULATED	6006377
11	1	COVER PLATE - X CONTROLLER	6013870
12	1	X CONTROLLER PCB W/ MLS PROGRAM	6014053
		X CONTROLLER PCB W/ AMLS PROGRAM	6014055
		X CONTROLLER PCB W/ ALS PROGRAM	6014047
13	2	TERMINAL BLOCK, 9 POS	6008824
14	2	TERMINAL BLOCK, 4 POS	6008822
15	1	TRANSFORMER,CONTROL 120/17 50VA	6008636
16	2	TERMINAL, END STOP, SCREWLESS	6000549
17	1	TERMINAL, 2 POLE	6000542
18	1	TERMINAL BLOCK, FUSED DISCONNECT	6000538
19	1	FUSE MDL 0.5A (NOT SHOWN)	6008836
20	1	TERMINAL END PLATE, 2MM	6006848
21	1	END AND INTERMEDIATE PLATE 2.5MM	6008853
22	1	RELAY SOCKET FINDER 95.85.1	6000522
23	1	MINIATURE PCB RELAY 24VDC	6000520
24	1	CONTROL PANEL DECAL ALS 2 KELLEY	6013950
		CONTROL PANEL DECAL ALS KELLEY	6013950
		CONTROL PANEL DECAL ALS 2 SERCO	6013948
		CONTROL PANEL DECAL ALS SERCO	6013948
		CONTROL PANEL DECAL AMLS SERCO	6014253
		CONTROL PANEL DECAL AMLS KELLEY	6014252
		CONTROL PANEL DECAL MLS SERCO	6014255
		CONTROL PANEL DECAL MLS KELLEY	5014254
25	1	LUG, GROUNDING, 4-14 ALUMINUM	6008813

PARTS LIST — EXTERIOR SIGN AND LIGHTS

Fig. 28

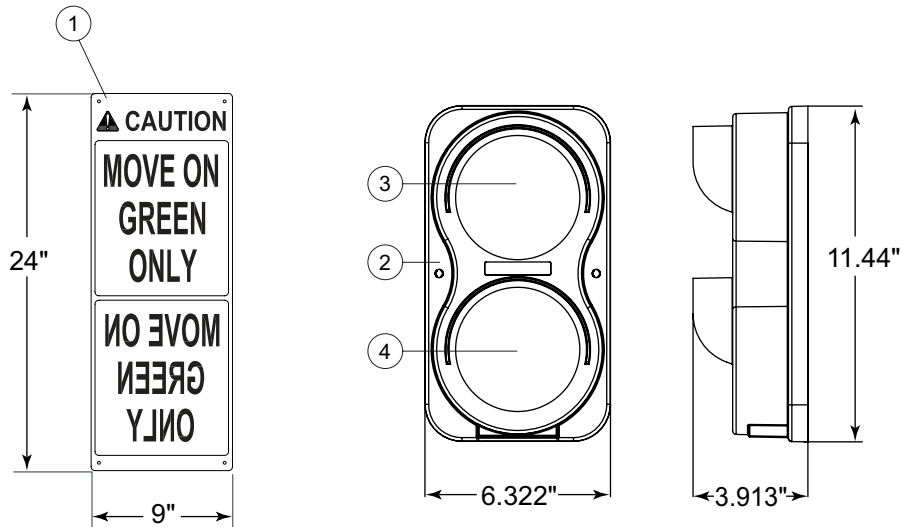

Item	Quantity	Part Description	Part Number
1	1	Outside Sign – Normal and Reverse Lettering	709-832
2	1	Light Assembly - Complete (LEDs)	6007798
3*	1	Red LED Light Assy.	6007800
4*	1	Green LED Light Assy.	6007801

* Part of Item 2 (Light Assembly – Complete).

LIMITED WARRANTY

4FRONT ENGINEERED SOLUTIONS, INC. warrants that this LIGHT SYSTEM will be free from flaws in material and workmanship under normal use for a period of one (1) year from the earlier of 1) 60 days after the date of initial shipment by 4FRONT ENGINEERED SOLUTIONS, INC., or 2) the date of installation of the LIGHT SYSTEM by the original purchaser, provided that the owner maintains and operates the LIGHT SYSTEM in accordance with this User's Manual. In the event that this LIGHT SYSTEM proves deficient in material or workmanship within the applicable limited warranty period, 4FRONT ENGINEERED SOLUTIONS, INC. will, at its option:

1. Replace the LIGHT SYSTEM, or the deficient portion of either, without charge to the owner (excluding any cost of removal or reinstallation which shall be the sole responsibility of the purchaser); or
2. Alter or repair the LIGHT SYSTEM, on site or elsewhere, without charge to the owner.

The limited warranty stated in the preceding paragraph IS EXCLUSIVE AND IT IS IN LIEU OF ANY OTHER GUARANTEES AND WARRANTIES, EXPRESS OR IMPLIED. The limited warranty does not cover any failure caused by improper installation, abuse, negligence, or failure to maintain and adjust the LIGHT SYSTEM properly. Parts requiring replacement due to damage resulting from vehicle impact, abuse, or improper operation are not covered by this warranty. 4FRONT ENGINEERED SOLUTIONS, INC. disclaims any responsibility or liability for any loss or damage (including, without limitation, direct, indirect or consequential damages, or lost profits or production time) that results from the use of unauthorized replacement parts or modification of the LIGHT SYSTEM. 4FRONT ENGINEERED SOLUTIONS, INC. sole obligation with regard to a LIGHT SYSTEM that proves to be deficient in material or workmanship shall be as set forth in its standard warranty above (i.e., 4FRONT ENGINEERED SOLUTIONS, INC. will, at its option, repair or replace the LIGHT SYSTEM or portion thereof, without charge to the purchaser.).

This limited warranty does not cover any failure caused by improper installation, abuse, negligence, or failure to properly maintain and adjust the LIGHT SYSTEM. This limited warranty will be void or of no effect if the original purchaser does not notify 4FRONT ENGINEERED SOLUTIONS, INC. warranty department within ninety (90) days after the product deficiency is discovered. Parts requiring replacement due to damage resulting from vehicle impact, abuse, or improper operation are not covered by this warranty. 4FRONT ENGINEERED SOLUTIONS, INC. disclaims any responsibility or liability for any loss or damage that results from the use of unauthorized replacement parts or modification of the LIGHT SYSTEM.

THERE ARE NO WARRANTIES, EXPRESS OR IMPLIED, WHICH EXTEND BEYOND THE DESCRIPTION ON THE FACE HEREOF, AND THERE IS NO WARRANTY OF MERCHANTABILITY OR OF FITNESS FOR A PARTICULAR PURPOSE.

4FRONT ENGINEERED SOLUTIONS, INC. warranties extend only to the LIGHT SYSTEM itself.

4FRONT ENGINEERED SOLUTIONS, INC. DISCLAIMS all warranties, express or implied, responsibility or liability for loss or damage of any kind associated with the installation or maintenance of the LIGHT SYSTEM, including any liability for premature product wear, product failure, property damage or bodily injury arising from improper installation or maintenance of the LIGHT SYSTEM.

Please direct questions about your light system to your local distributor.

Your local distributor is:

Corporate Head Office:

1612 Hutton Dr. Suite 140

Carrollton, TX. 75006

Tel. (972) 466-0707

Fax (972) 323-2661