

MECHANICAL

EDGE-OF-DOCK SPECIFICATIONS



Design Highlights

- Exclusive Lug Style Lip Hinge provides superior strength and extended life
- High Strength Steel Tread Plate (Ramp & Lip)
- Robotic Welding for improved strength, quality and consistency
- Reliable Dual Extension Spring Lifting Mechanism
- Ergonomic Design – Easy operation that requires less lifting force
- Exclusive EZ-Lift™ Spring Assist on Lip Hinge reduces lifting force
- Heavy Duty Steel Lifting Handle with Safety Grip
- Operating Range is 5" (127 mm) above to 5" (127 mm) below dock
- Effective Working Range is 3" (76.2 mm) above to 3" (76.2 mm) below dock
- Lower Profile Design reduces interference with material handling equipment
- Beveled Lip Edge (11 degrees) provides smooth interface with trailers
- 15" (381 mm) Lip Standard (Optional 17" (432 mm) lip available for refrigerated trailers)
- Tire Laminated Bumpers mounted to steel bumper blocks
- Exclusive EZ-Hang™ installation system simplifies install
- Integral Maintenance / Service Strut

Project Information

Job Name _____
Address _____
General Contractor _____
Distributor _____
Model _____ Quantity _____

Certified For Construction

By _____
Company _____
Address _____
Date _____

Available Options

- 17" (432 mm) Lip for refrigerated trailers
- Post Office Model with 2" (51 mm) cart guard
- Steel faced bumpers
- Tapered Lip (tapered on each side)
- Recessed Pit Model
- Special Surface Finish
- Bumper Projection 16", 17" or 18"
(406, 432 or 457 mm) _____

Accessories

- Embed Channel or Transition Steel: _____
- Vehicle Restraint – Model: _____
- Dock Seal or Shelter – Model: _____
- Other: _____



MECHANICAL

EDGE-OF-DOCK SPECIFICATIONS

1. General: Unit meets or exceeds MH14.1-1987 performance requirements.

2. Construction: Deck and lip to be 3/8" (9.52 mm) to 1/2" (12.7 mm) thick (depending upon capacity) high tensile steel tread plate. Conforms to ANSI/MH14.1 1987 performance requirements. Self-cleaning lug-style front lip hinge with heavy-duty lugs robotically welded to ramp assembly. Ramp assembly projects 13" (330 mm) from dock in the stored position and the standard lip length is 15" (381 mm). Dual extension spring lift mechanism offers reliability and ease of operation and operating handle is 1 5/16" (33.3 mm) diameter steel pipe.

3. Bumpers: Unit to include two 4"x10"x12" (101mm x 254mm x 305mm) tire laminated bumpers mounted to steel block assemblies. Bumper projections available in 16", 17" and 18" (406, 432 & 457 mm). See chart below for bumper projections.

4. Working Range: Operating range is 5" (127 mm) above to 5" (127 mm) below dock level. Effective working range is 3" (76.2 mm) above and 3" (76.2 mm) below dock level*

5. Operation: Simple pull of the activation handle raises the ramp into position. Attendant easily pushes the handle forward to extend the lip into the trailer. The unit can be stored by again pulling the handle to remove the lip from the trailer.

6. Installation: Unit ships completely assembled for easy installation. Unit to be securely welded to a channel (8" (203 mm) minimum) embedded in concrete and secured with anchoring hooks as recommended. Instructions are defined in the product's Owner's Manual.

7. Limited Warranty: Warranted against defects in materials and workmanship for one year.

* Due to the limited length of EOD levelers, its structure is subjected to greater dynamic load than with longer levelers. Capacity selection is based on ideal operating conditions (i.e. maximum gross load traveling at 3 m.p.h. on 10% grade or less); if the application exceeds this condition a higher capacity leveler must be selected.

NOMINAL DIMENSIONS			
MODEL	WIDTH	LENGTH	CAPACITY
SM6620	66" (1676 mm)	27" (686 mm)	20,000 lbs. (9091 Kg)
SM6630	66" (1676 mm)	27" (686 mm)	30,000 lbs. (13,636 Kg)
SM7220	72" (1829 mm)	27" (686 mm)	20,000 lbs. (9091 Kg)
SM7230	72" (1829 mm)	27" (686 mm)	30,000 lbs. (13,636 Kg)
SM7830	78" (1981 mm)	27" (686 mm)	30,000 lbs. (13,636 Kg)
SM8430	84" (2134 mm)	27" (686 mm)	30,000 lbs. (13,636 Kg)

Channel and Anchor Detail

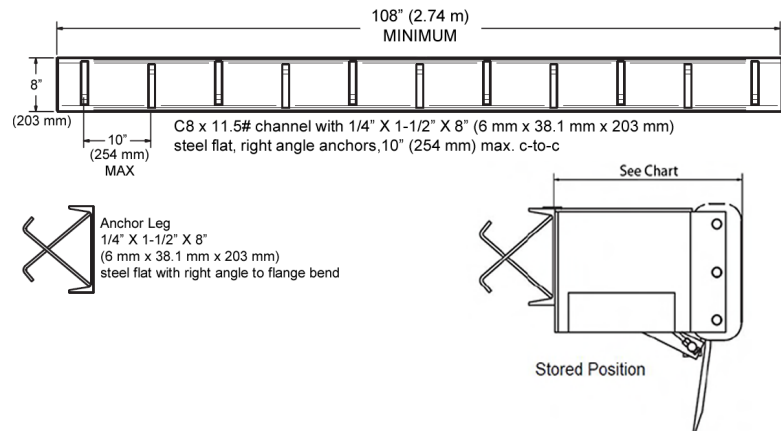

A	B
66" (1.68 m)	98" (2.49 m)
72" (1.83 m)	104" (2.64 m)
78" (1.98 m)	110" (2.80 m)
84" (2.13 m)	116" (2.95 m)

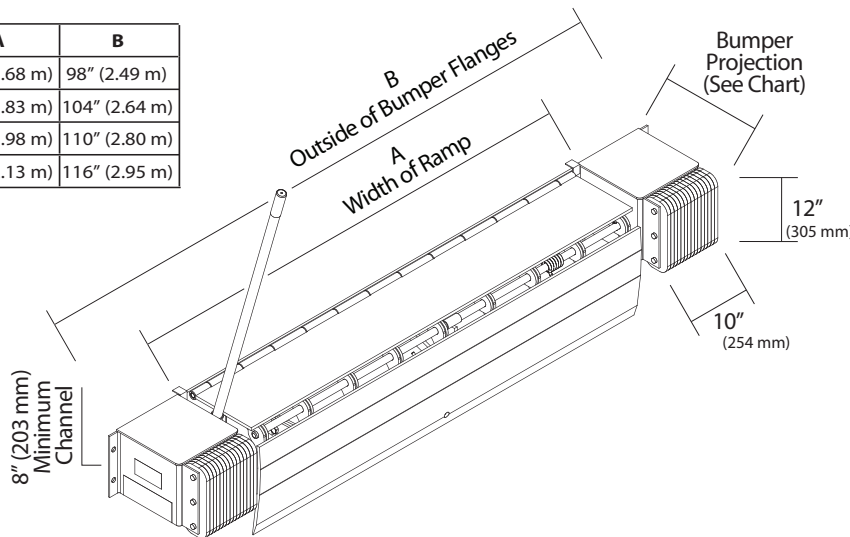

BUMPER PROJECTIONS		
LIP LENGTH	CROWN	PROJECTION
15" (381 mm)	5°	16" (406 mm)
15" (381 mm)	8°	16" (406 mm)
17" (432 mm)	2.5°	18" (457 mm)
17" (432 mm)	5°	17" (432 mm)
17" (432 mm)	8°	16" (406 mm)

