

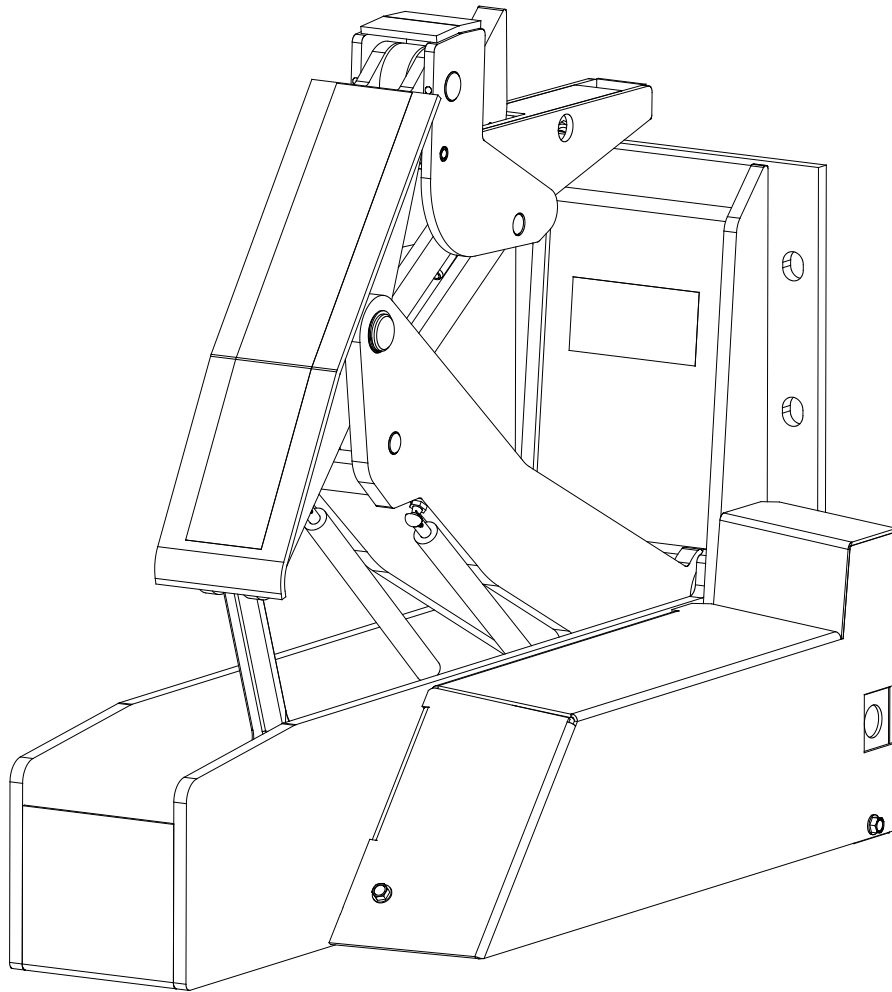

Vehicle Restraints

PitBull® SAFETY-LOC®

SL60



This manual applies to PitBull® SAFETY-LOC® vehicle restraints manufactured beginning June 2018 with the serial numbers 61317148 and higher.

⚠ WARNING

Do not install, operate or service this product unless you have read and understand the Safety Practices, Warnings, and Installation and Operating Instructions contained in this manual. Failure to do so could result in death or serious injury.

User's Manual

Installation, Operations, Maintenance and Parts

Part No. 6016092B

TABLE OF CONTENTS

Introduction.....	2	Adjustments	
Safety Signal Words.....	2	Proximity Sensor Locations.....	31
Safety Practices.....	3	Restraint Stored Sensor (LS1).....	32
Installation.....	4	Restraint Raised Sensor (LS2).....	33
Components and Specifications.....	16	RIG Sensor Bar (LS4).....	34
Electrical System Operation.....	17	Gas Spring Replacement.....	35
Operating Instructions		Electrical Schematic	
Engaging Vehicle.....	19	SL60.....	37
Releasing Vehicle.....	20	Parts List	
No RIG (rear impact guard).....	20	Vehicle Restraint.....	38
High RIG (rear impact guard).....	20	Control Panel.....	42
Planned Maintenance.....	21	Exterior Sign and Lights.....	44
Lubrication.....	22	Warranty Information.....	47
Troubleshooting Guide.....	23	Distributor Information.....	48
PLC Diagnostics.....	26		

INTRODUCTION

Welcome and thank you for choosing this vehicle restraint from Serco Entrematic.

This User's Manual contains information that you need to safely install, operate and maintain the vehicle restraint. It also contains a complete parts list and information about ordering replacement parts. Please **keep and read this User's Manual** before using your new vehicle restraint.

SAFETY SIGNAL WORDS

You may find safety signal words such as DANGER, WARNING, CAUTION or NOTICE throughout this User's Manual. Their use is explained below:



This is the safety alert symbol. It is used to alert you to potential personal injury hazards. Obey all safety messages that follow this symbol to avoid possible death or injury.

DANGER

Indicates an imminently hazardous situation which, if not avoided, will result in death or serious injury.

WARNING

Indicates a potentially hazardous situation which, if not avoided, could result in death or serious injury.

CAUTION

Indicates a potentially hazardous situation which, if not avoided may result in minor or moderate injury.

NOTICE

Notice is used to address practices not related to personal injury.

SAFETY PRACTICES

⚠ WARNING

Read these safety practices before installing, operating or servicing the PitBull® SAFETY-LOC®. Failure to follow these safety practices could result in death or serious injury.

READ AND FOLLOW THE OPERATING INSTRUCTIONS IN THIS MANUAL BEFORE OPERATING THE PITBULL® SAFETY-LOC®. If you do not understand the instructions, ask your supervisor to teach you how to use the vehicle restraint.

Be certain to follow the instructions in this manual.

INSTALLATION AND OPERATION

Do not use this vehicle restraint until you have received proper training. Improper use could result in property damage, bodily injury and/or death. Read and follow the complete OPERATING INSTRUCTIONS on pages 19 and 20 before use. If you do not understand the instructions, ask your supervisor to explain them to you or call your authorized Serco Entrematic distributor.

DO NOT USE THE VEHICLE RESTRAINT IF IT APPEARS DAMAGED OR DOES NOT OPERATE PROPERLY. Inform your supervisor immediately.

Do not operate the vehicle restraint until all bystanders are clear of all moving parts.

Do not install the vehicle restraint anchor bolts into aged or unsound concrete. Improper installation of the vehicle restraint could result in death or serious injury to dock workers or other users of the vehicle restraint.

Do not load or unload any vehicle unless you make certain the vehicle restraint has securely engaged the RIG (rear impact guard) of the vehicle and set the brakes. If the vehicle restraint does not engage the RIG for any reason, **BE CERTAIN TO CHOCK THE VEHICLE WHEELS BEFORE LOADING OR UNLOADING.**

Before chocking vehicle wheels or engaging vehicle restraint, dump air from air ride suspensions and set parking brake.

MAINTENANCE AND SERVICE

If the vehicle restraint does not operate properly using the procedures in this manual, **BE CERTAIN TO CHOCK THE VEHICLE WHEELS AND ENSURE THE BRAKES ARE SET BEFORE LOADING OR UNLOADING.** Call your local Serco ENTREMATIC distributor for service.

Place barricades around the pit on the dock floor and driveway while installing, maintaining or repairing vehicle restraint restraining device.

Do not stand in the driveway between the dock and a backing vehicle.

Do not use the vehicle restraint as a step.

Keep hands and feet clear of moving parts at all times.

If equipped with heater, there is a possible burn hazard if turned on.

All electrical troubleshooting and repair must be done by a qualified technician and meet all applicable codes.

Disconnect the power and properly tag or lock off before doing any electrical work.

If it is necessary to make troubleshooting checks inside the control box with the power on, **USE EXTREME CAUTION.** Do not place fingers or uninsulated tools inside the control box. Touching wires or other parts inside the control box could result in electrical shock, death or serious injury.

If you have any problems or questions, contact your local Serco Entrematic distributor for assistance.

INSTALLATION

MOUNTING CONSIDERATIONS

⚠ WARNING

Before installation read and follow the Safety Practices on page 3. Failure to follow these safety practices could result in death or serious injury. READ AND FOLLOW THE OPERATION INSTRUCTIONS IN THIS MANUAL BEFORE OPERATING THE VEHICLE RESTRAINT. If you do not understand the instructions, ask your supervisor to teach you how to use the vehicle restraint.

Improper installation of the vehicle restraint could result in death or serious injury to dock workers or other users of the vehicle restraint.

Place barricades around pit on dock floor and drive while installing, maintaining or repairing vehicle restraining device.

Be certain bystanders in the driveway stand clear when the vehicle restraint is operated.

Be certain to follow the installation instructions in this manual.

Do not install the vehicle restraint anchor bolts into aged or unsound concrete.

1. The surface on which the vehicle restraint will be mounted must be flat to prevent binding of the mechanism. If the mounting surface is not flat, it may be necessary to use shims or physically modify the dock face or driveway to provide a flat mounting surface.

PitBull® Safety-Loc® restraints require a 4" bumper projection from the front of the bumper to the rear of the back plate of the restraint (the mounting surface). Less than 4" of projection can allow vehicle RIG bar to damage the restraint.

2. The standard anchors included with this product may only be used on docks constructed of solid concrete. Docks constructed with other materials require special mounting consideration. Contact your local Serco Entrematic distributor for information.

TOOLS REQUIRED

- Welder
- Impact or rotary hammer drill with 3/4" diameter concrete drill bit, (also 7/8" diameter if driveway mount option is to be installed)
- 1-1/8" inch wrench
- General hand tools
- Touch-up paint (Cold spray galvanizing)
- Torque wrench (110 ft lb min.)
- 1-1/8" deep socket
- Rebar cutting drill bit (3/4" or 7/8") with rotary-only drill motor
- Threaded rod installation tool for rotary hammer drill with 3/4" coupler (driveway mount only).

Fig. 1

CONCRETE DOCK FACE (Standard installation)

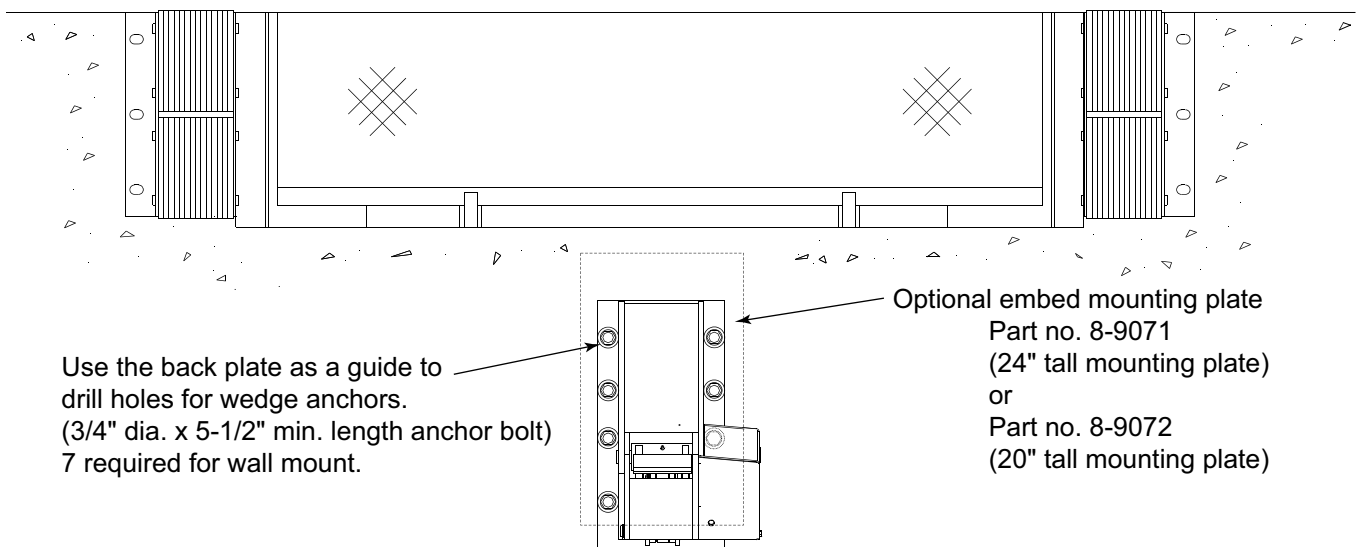

⚠ WARNING

Inadequate lifting equipment or practices can cause a load to fall unexpectedly. Make sure the lifting chain or other lifting devices are in good condition and have a rated capacity of at least 500 lbs. Never allow anyone to stand on or near the restraint when it is lifted or positioned. Stand clear of the vehicle restraint when it is positioned. Failure to follow this warning can allow the restraint to fall, tip, or swing into people, which could result in death or serious injury.

Fig. 2

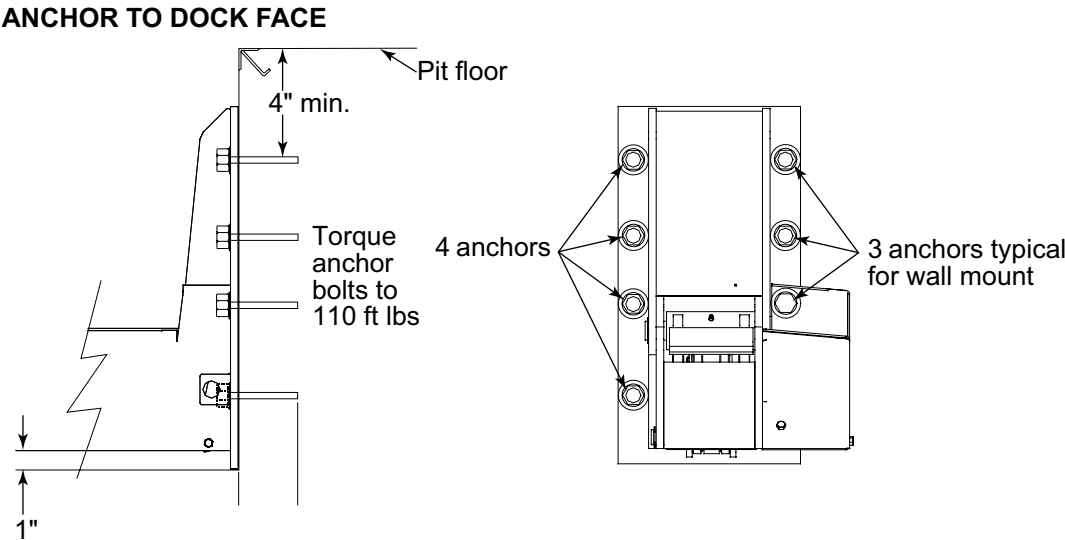
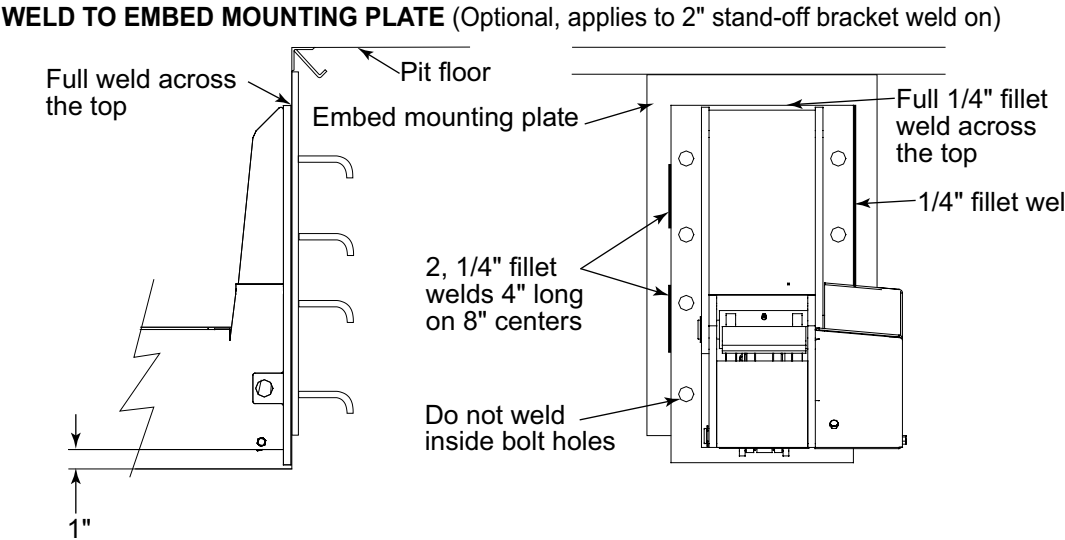

Fig. 3



INSTALLATION, continued

⚠ WARNING

Do not install, operate, or service this product unless you have read and followed the Safety Practices, Warnings, and Installation and Operating Instructions contained in this manual. Failure to do so could result in death or serious injury. ALWAYS USE DOCK LEVELER SUPPORT WHEN WORKING UNDER A DOCK LEVELER RAMP OR LIP.

Place barricades around pit on dock floor and drive while installing, maintaining or repairing dock leveler or vehicle restraint.

Improper installation of anchoring devices or installation into aged or unsound concrete could result in death or serious injury.

Inadequate lifting equipment or practices can cause a load to fall unexpectedly. Make sure the lifting chain or other lifting devices are in good condition and have a rated capacity of at least 500 lbs for the lifting angle used. Never allow anyone to stand on or near the restraint when it is lifted or positioned. Stand clear of the vehicle restraint when it is positioned. Failure to follow this warning can allow the restraint to fall, tip, or swing into people, which could result in death or serious injury.

Improper installation that allows the pendant dock leveler lip to support the weight of the dock leveler on the vehicle restraint could result in death or serious injury.

WALL MOUNT (Standard Installation)

1. Place the vehicle restraint on the driveway. See Fig. 1. Center it on the dock position. Operate the dock leveler with the vehicle restraint in its intended position to assure there is no interference. Make sure the lip, when in the storage position, does not interfere. Use the back plate as a guide to drill the 7 holes for the 3/4" diameter wedge anchors, see Fig. 2 and 11. Install the wedge anchors per installation instructions on page 10. Place the anchors in the holes as they are drilled to prevent the vehicle restraint from shifting during drilling. Ensure back plate lies flat with dock face - shim if necessary. Torque the anchors to 110 ft. lbs.

⚠ WARNING

Improper installation that allows a pendant dock leveler lip to be supported by the restraint could result in death or serious injury. Install lip deflector plate(s) as required to avoid any chance of the pendant lip storing on top or behind the restraint backplate (see Fig. 4). Materials supplied by the installer.

2. If steel embed plate is used, see instructions in Fig. 1 and 3.

⚠ WARNING

Ensure area is well-ventilated when welding galvanized metal, fumes may be toxic.

3. For low dock installations reference Fig. 4-6. If the top anchor positions are less than 4" from the pit floor, do not install them. Install pit floor mounting plate (requires four 3/4" anchors, supplied by others) and weld to the back of the restraint as shown in Fig. 5 and 6.

INSTALLATION WITH EDGE-OF-DOCK TYPE LEVELERS

4. Stand-off or edge-of-dock levelers require a special stand-off to be used between the vehicle restraint and the dock face to maintain the min. 4" bumper projection from the front of the bumper to the rear of the back plate of the restraint (the mounting surface). See Fig. 7 and 8.

DRIVEWAY MOUNT (Optional Installation)

1. If the dock face is not suitable for anchoring, a driveway mount option is available. A special concrete pad must be poured if sound concrete at least 8" thick is not available on the driveway. See Fig. 9 and 10 for pad details. Place the vehicle restraint on the driveway, center it on the dock position. Operate the dock leveler with the vehicle restraint in its intended position to ensure there is no interference. Make sure the lip when in the storage position does not interfere.
2. Use the restraint rear base plate as a guide to drill the four 7/8" diameter x 6-5/8" deep holes for the four chemical anchors supplied by Serco Entrematic. Use the front base plate as a guide for drilling the 3/4" diameter holes for the two 3/4" x 7" wedge anchors supplied by Serco Entrematic. See Fig. 9, 10 and 12. Place the front anchors in the holes as they are drilled to prevent the vehicle restraint from shifting during drilling. Torque the wedge anchors to 110 ft. lbs.
3. Install the chemical anchors per installation instructions on page 11.

INSTALLATION, continued

Fig. 4 **LOW DOCK HEIGHT**

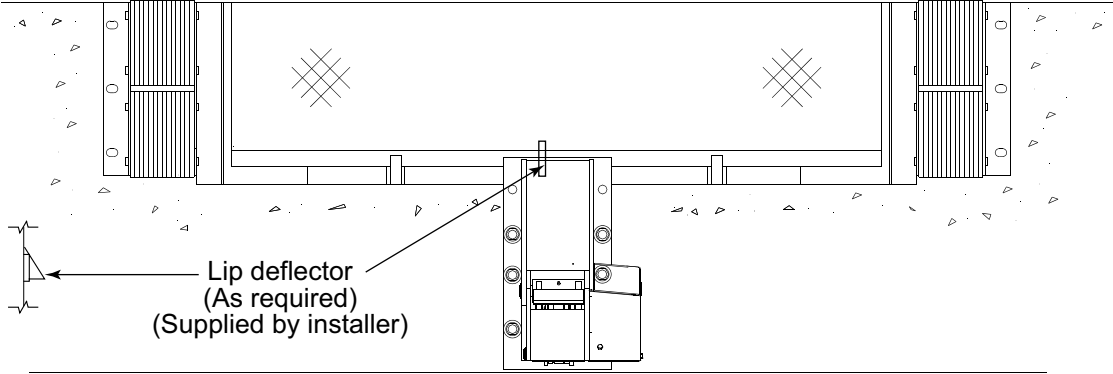
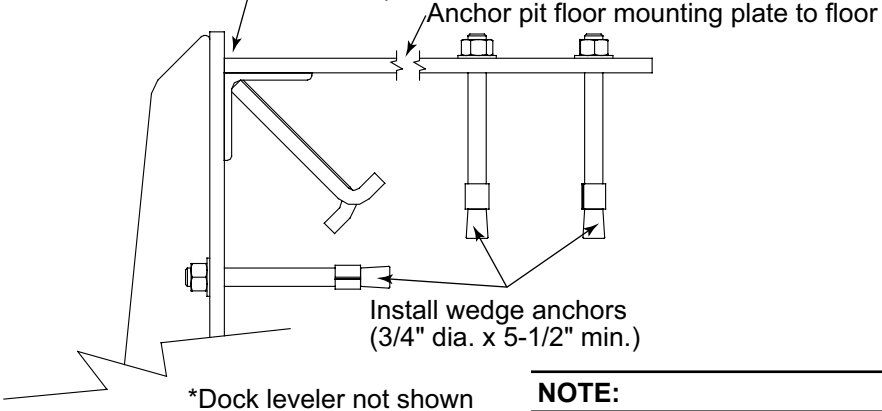

Fig. 5 (Weld pit floor mounting plate to lock unit back plate with a continuous 1/4" fillet weld.)



NOTE:

If top anchor positions in the mounting plate are less than 4" from the pit floor do not install as concrete may fracture. Install pit floor mounting plate (requires 4 anchors) and weld to the back of the mounting plate or to the curb angle as shown. (pit floor mounting plate part no. 586-2935)

Fig. 6 Weld to curb angle with a continuous 1/4" weld

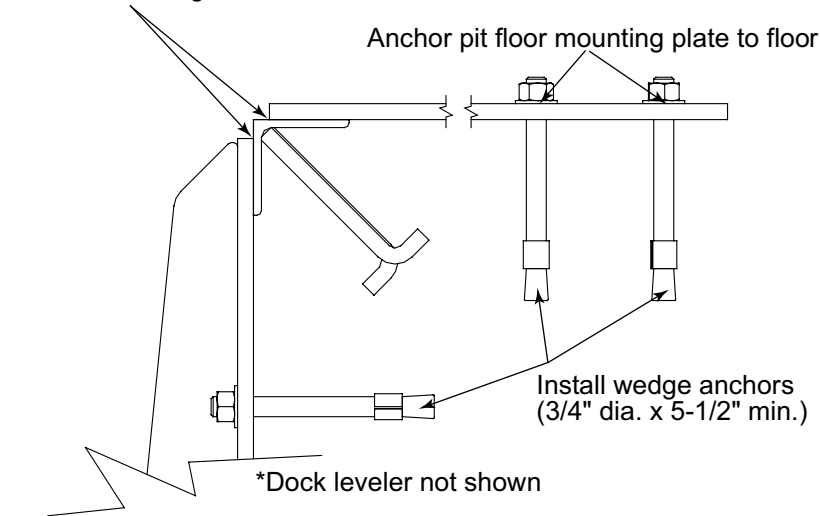

INSTALLATION, continued

Fig. 7

CANTILEVERED OR EDGE-OF-DOCK LEVELER

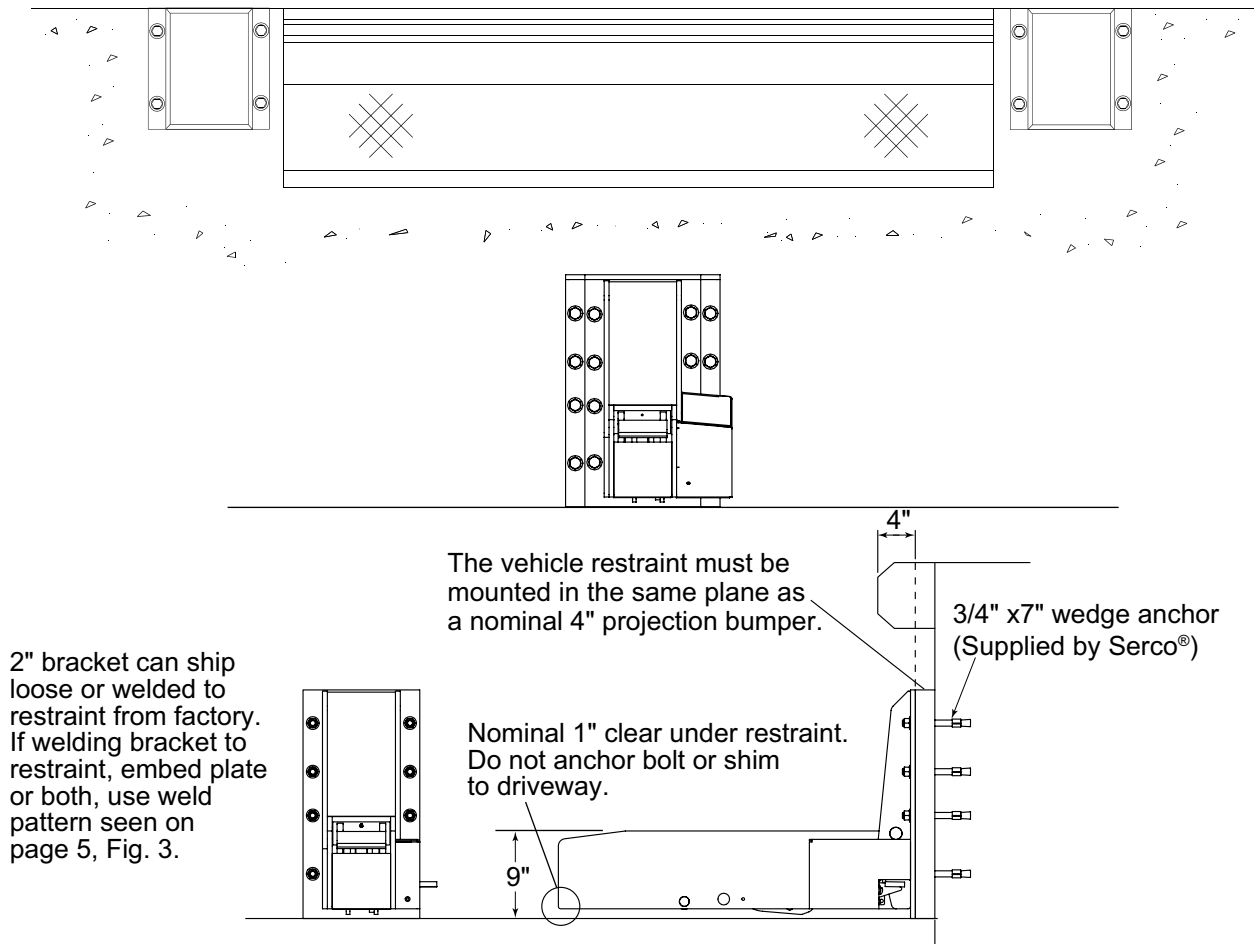
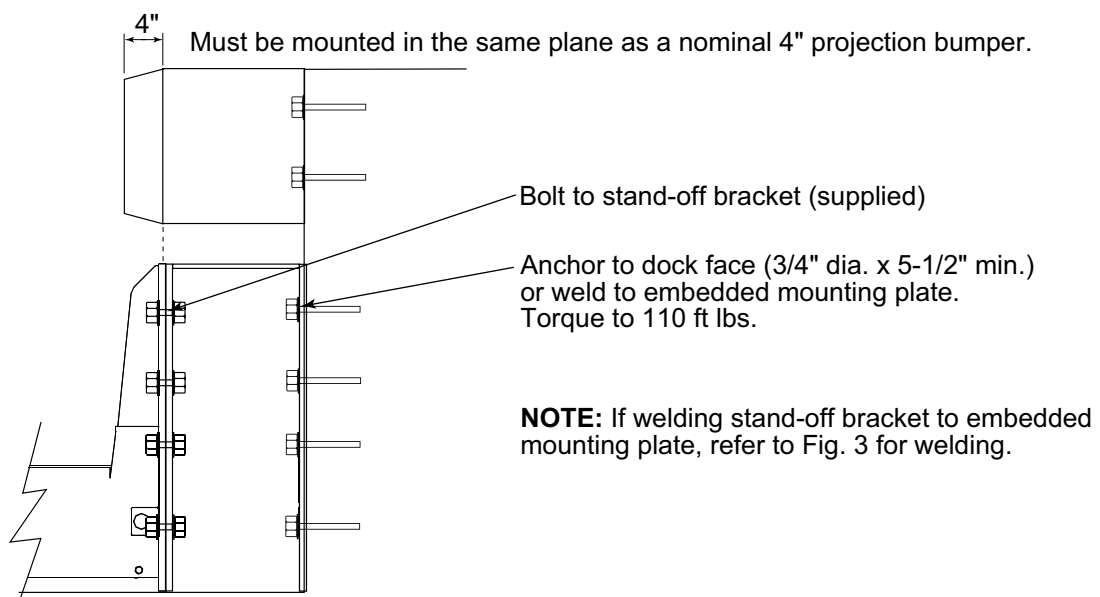

Fig. 8



⚠ WARNING

Concrete pad size shown is a general recommendation in size so that the vehicle weight is on pad. Due to different soil, drainage and drive conditions, a civil engineer must be consulted to detail the correct pad size for the particular application. Failure to do so may cause the pad to fail to hold the restraint in place and could result in death or serious injury.

Fig. 9 **DRIVEWAY MOUNT** (Recommended when dock face is not suitable for lock mounting)

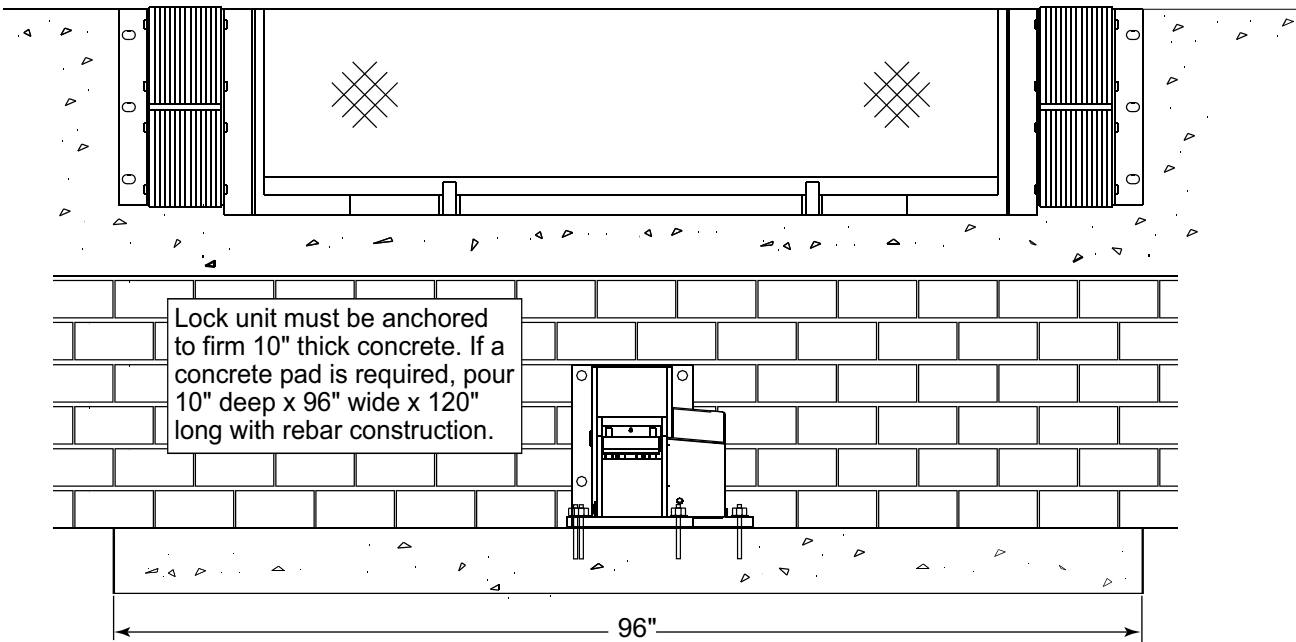
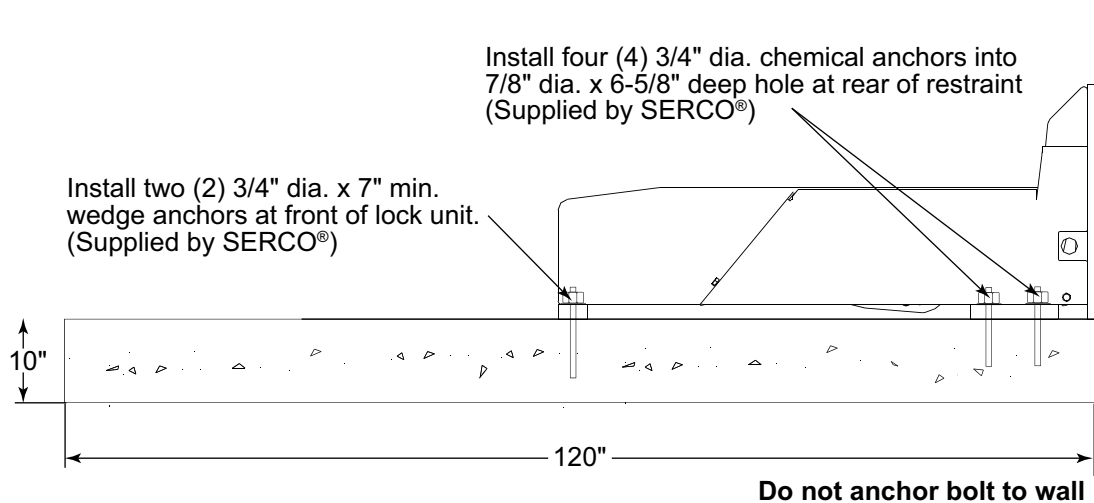

Fig. 10



INSTALLATION, continued

WEDGE ANCHOR INSTALLATION (STANDARD INSTALLATION)

Fig. 11

⚠ WARNING

Do not install the vehicle restraint anchor bolts into aged or unsound concrete.

Use standard anchors on smooth 4,000 PSI concrete walls only. For aggregate, cinder block or tilt walls - consult factory.

⚠ CAUTION

Oversized holes in the base material will make it difficult to set the anchor and will reduce the anchor's load capacity.

NOTICE

Do not use an impact wrench to set or tighten the wedge anchors.

Drill a hole in the concrete using a carbide drill bit the same diameter as the nominal diameter of the anchor to be installed. Drill the hole to the specified embedment depth and blow it clean using compressed air. Alternatively, drill the hole deep enough to accommodate embedment depth and dust from drilling. Assemble the anchor with nut and washer so the top of the nut is flush with the top of the anchor. Place the anchor in the fixture and drive into the hole until washer and nut are tight against fixture. Torque to 110 ft. lbs. See Fig. 11.

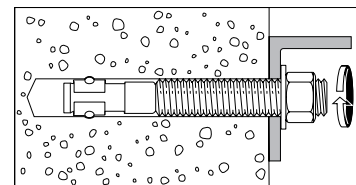
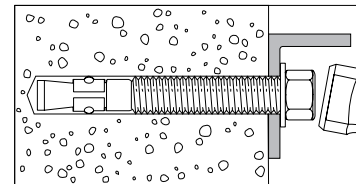
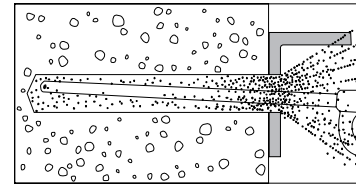
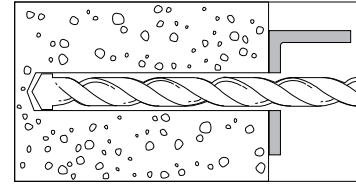

CHEMICAL ANCHOR INSTALLATION (GROUND MOUNTING ONLY)

Fig. 12

⚠ WARNING

Do not install the vehicle restraint anchor bolts into aged or unsound concrete.

1. Drill hole to correct size and depth using a rotary hammer.
2. Remove dust and rubble from the hole with compressed air, a brush, and water. Excess water must be removed although the hole may be damp.
3. Insert the capsule in the hole, resin end (long end) first.
4. Set anchor in hole by driving it through the capsule. Use only square-cut threaded rod. Do not spin the anchor while setting it.
5. Allow the anchor to set undisturbed for the cure time specified below.

RECOMMENDED CURING TIME

Concrete Temperature	Minimum Cure Time
68°F and over	10 minutes
50°F to 68°F	20 minutes
32°F to 50°F	1 hour
23°F to 32°F	5 hours
Below 23°F	Not Recommended

NOTE:

Anchors have a shelf life of 2 years.

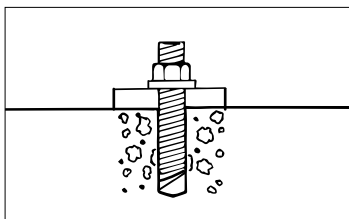
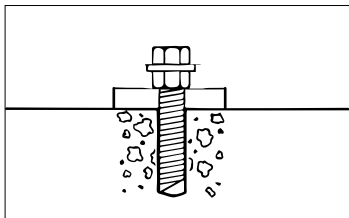
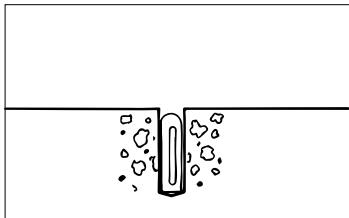
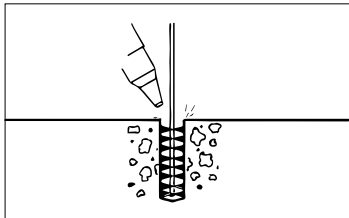
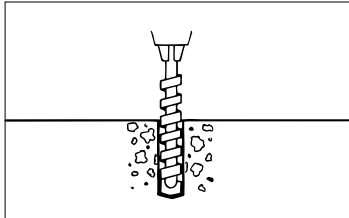

INSTALLATION, continued

⚠ WARNING

Before doing any electrical work, make certain the power is disconnected and properly locked or tagged off. Failure to do so may result in death or serious injury. All electrical work must be done by a qualified technician and must meet all applicable codes.

Do not route control wiring for any other device through this control box unless properly shielded.

Be certain power is off when wiring to the control box or signal lights. Failure to do so could result in electrical shock, death or serious injury.

ELECTRICAL INSTALLATION

NOTE:

Reference wiring diagrams on page 37 for all field connections.

1. Mount control box inside the building 5 feet above the floor, to the left of the doorway. See Fig. 13.

NOTICE

Connecting 24V lights to the 120V control panel terminals will destroy the light fixture.

NOTE:

For 120V exterior lights, use wiring kit 6003336. Installation instructions are included in the kit.

2. **Standard 24V exterior compact LED lights.**
Mount and wire outside 24V LED signal light assembly into the control box to output terminals OR for RED, OG for GREEN and OC for common. Terminals are located on the PLC. Always mount the light with the RED light on top and the GREEN light on the bottom.
3. Run 3/4" conduit from the vehicle restraint to the control panel. Junction box optional (supplied by others).
4. Run the six, color coded, factory connected wires from the terminal strip on the restraint to the control panel. Do not leave excessive slack in the wires or they will be damaged by moving parts. See Fig. 13 and 14.
5. Permanently mount the vehicle driver's instruction sign on the outside wall below the signal light when installing RED/GREEN Light Assembly. See Fig. 13.
6. Wire power to the control box through a fused disconnect (supplied by others) using terminals provided in the control box. See Fig. 13 and wiring diagram on page 37. Turn the power on.
7. Operate the vehicle restraint following the operating instructions on pages 19-20. Check for proper light operation, alarm operation (if equipped) and smooth operation according to the operating instructions.
8. Instruct the dock workers how to use the vehicle restraint using the operating procedures on pages 19-20.

INSTALLATION, continued

Fig. 14

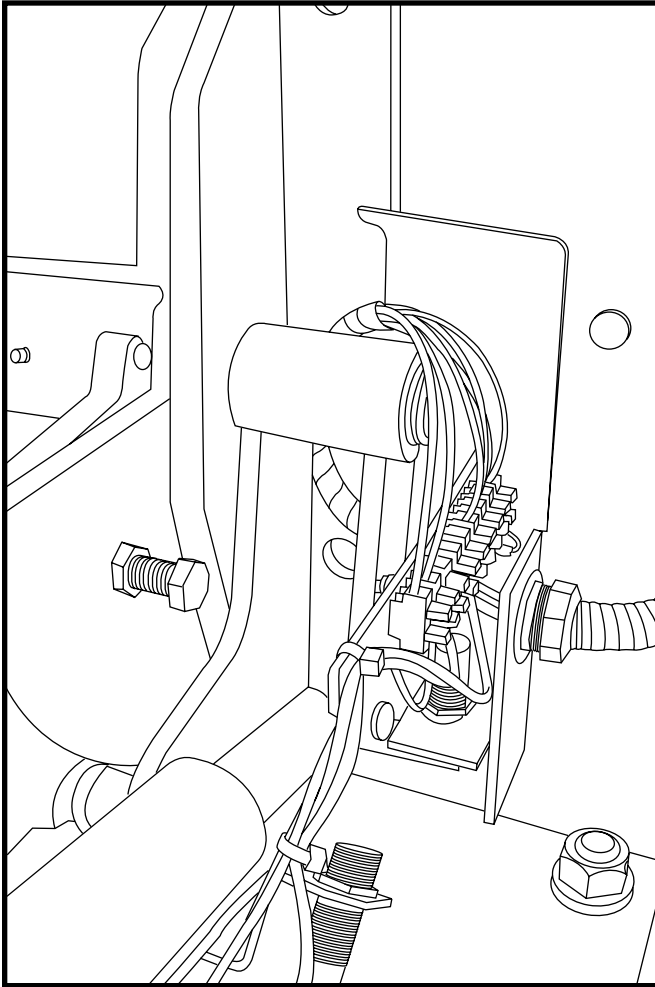

NEATLY ROUTED FIELD WIRING.

The control wires protected by the factory-supplied spiral-wrap sweep up behind and over the top of the sector plate. This will give years of reliable service.

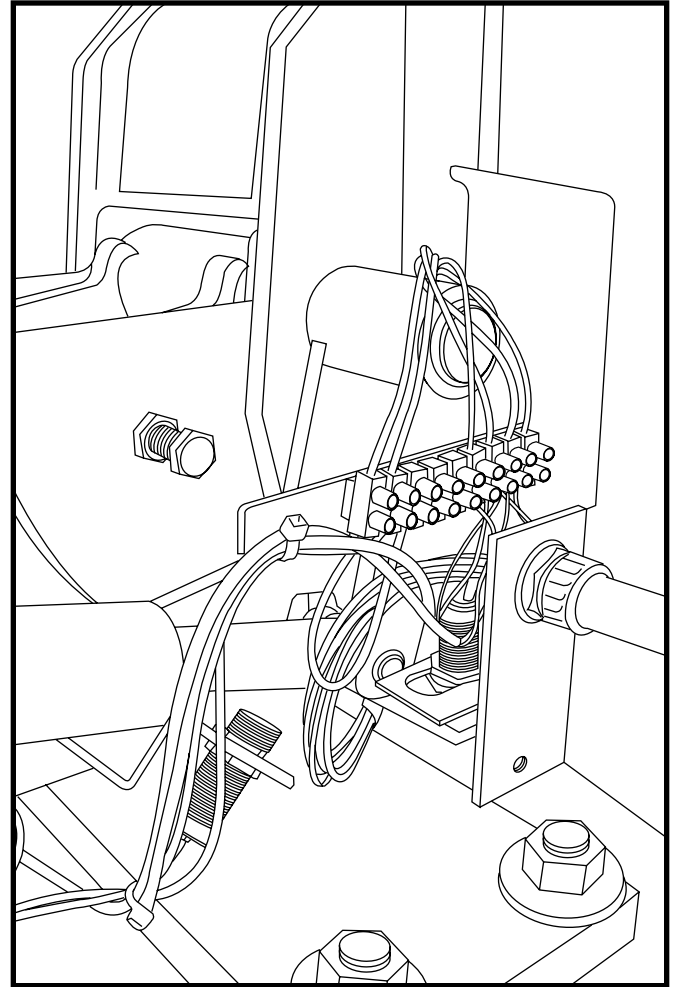

POORLY ROUTED FIELD WIRING.

Note how the six wires from the control panel are of excessive length. The sector plate will quickly shred these wires.

INSTALLATION, continued

FINAL INSTALLATION

LEVELER STORED SENSOR (optional)

The leveler stored sensor offers an optional interconnection between the dock leveler and the vehicle restraint. When installed the vehicle restraint cannot be lowered or released from lights only until the dock leveler has been stored.

Typical pit leveler installation for Serco Entrematic hydraulic levelers (except PAL). For all others, call your authorized distributor.

Assembly Number 99851

- A leveler stored sensor can be mounted beneath Serco Entrematic hydraulic dock levelers that have lip keepers as shown in Fig. 15.
- Weld the leveler stored sensor bracket as shown. Attach the face of the sensor so when the lip is stored the face of the sensor is 3/4" from lip for 6' and 8' levelers and 1" for 10' levelers.

Fig. 15

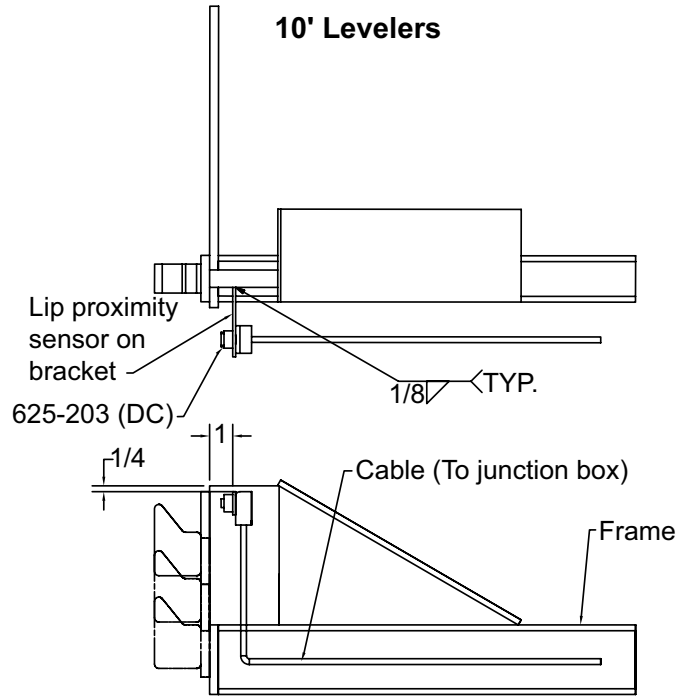
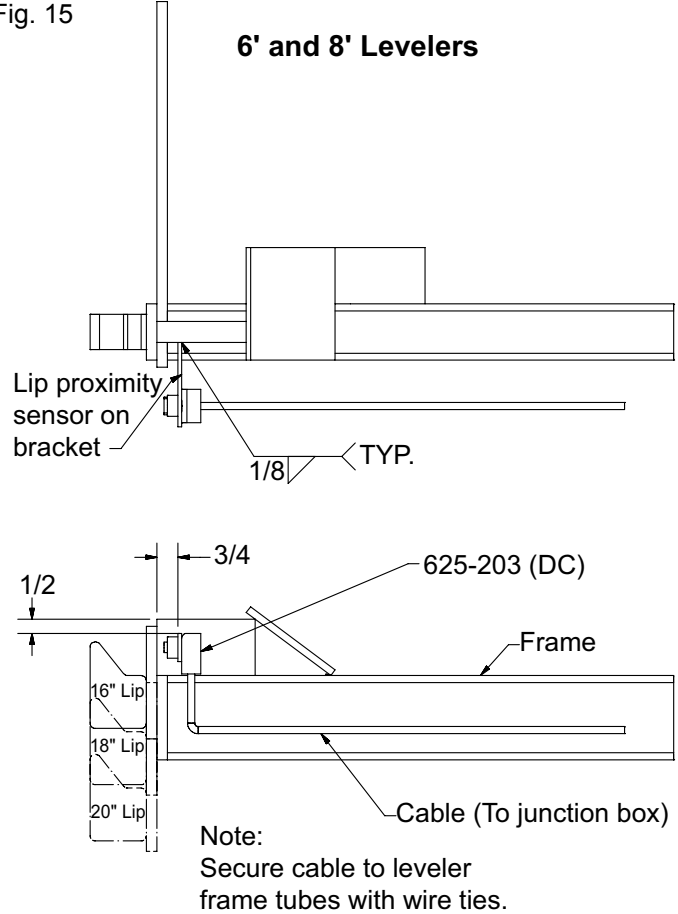

COMPONENTS AND SPECIFICATIONS

The main components of the vehicle restraint are shown below. See the parts list for specific part numbers.

Fig. 16

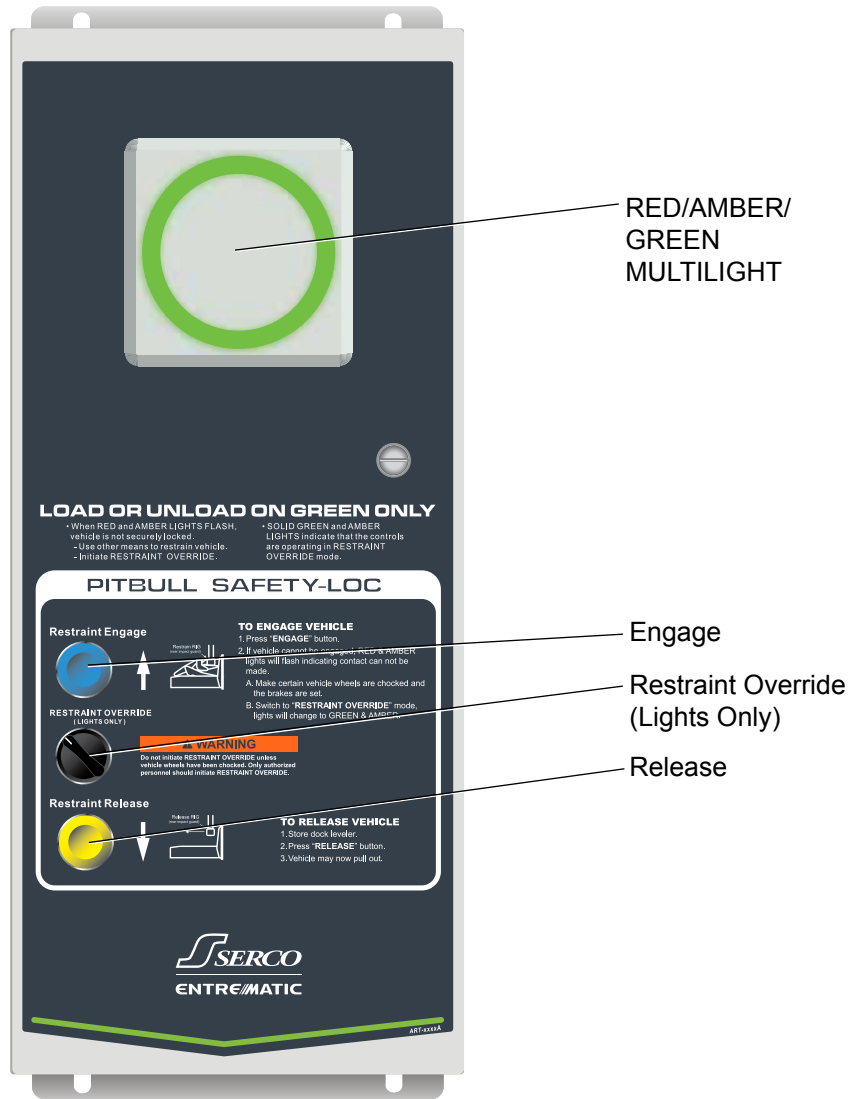

COMPONENTS AND SPECIFICATIONS, continued

Fig. 17

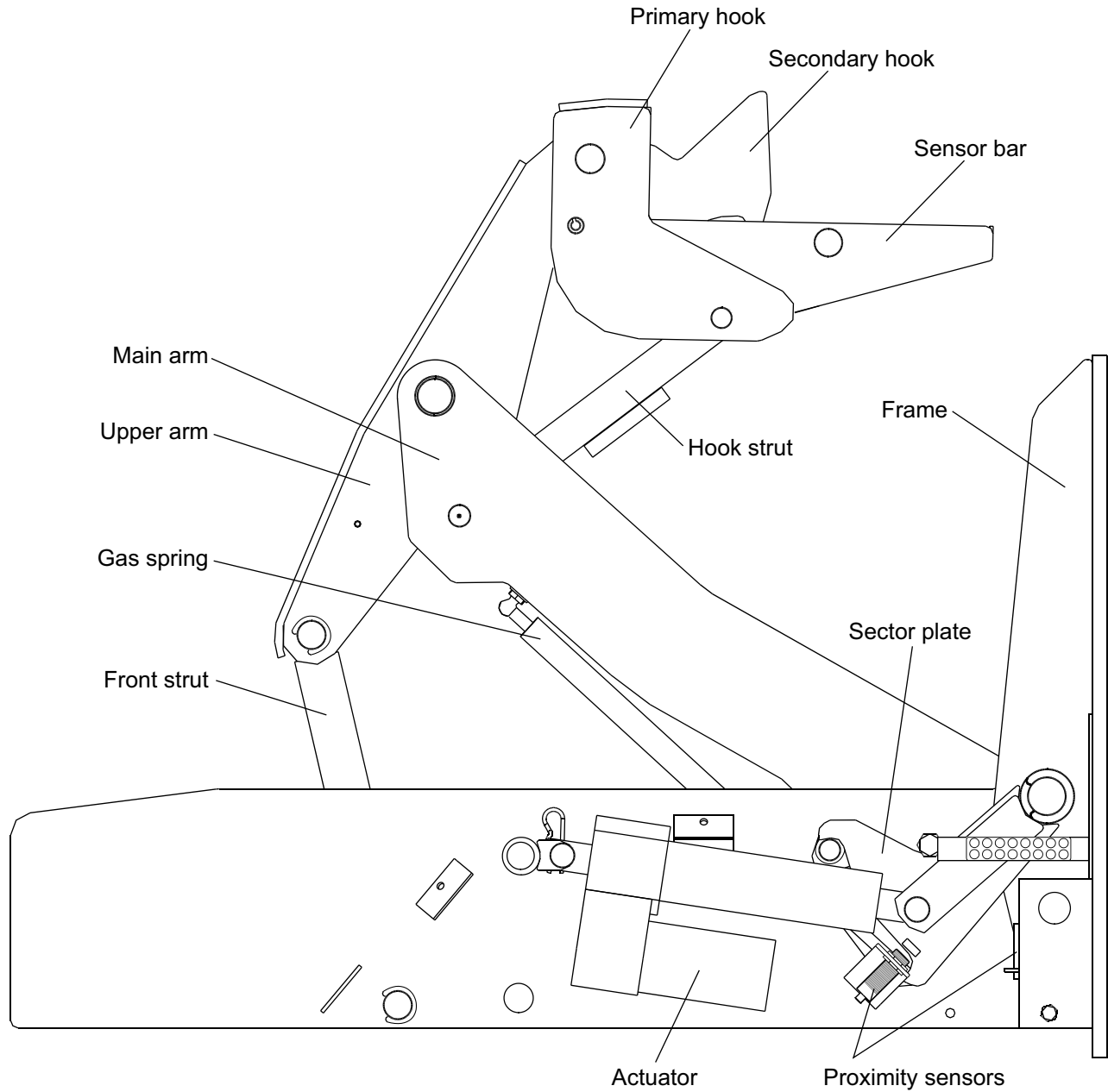

Control Panel - NEMA 12, Solid state PLC (Programmable Logic Controller), 120 VAC, FLA 3, UL and UL-C listed panel and components.

Linear Actuator (Raise/Lower) - 1000 lb load capacity, 24 VDC, 14 FLA, holding brake.

Proximity Sensors - NEMA 6P, normally open, with LED pilot light.

ELECTRICAL SYSTEM OPERATION

The following describes the operation of the electrical system when the controls are activated:

Fig. 18



ENGAGE

Press in

- Actuator starts.
- Hook raises to engage the RIG bar.
- Actuator stops when proximity sensor LS2 is reached.

RESTRAINT OVERRIDE (Lights Only) Turn Clockwise (Spring Return)

- Turn switch to right and release.
- Power is cut off from motor circuit.
- Power is supplied to outside RED light and inside GREEN and AMBER lights.

RELEASE

Press in

- Actuator starts.
- Hook lowers to stored position.
- Actuator stops when proximity sensor LS1 is reached.
- Returns system from **RESTRAINT OVERRIDE (Lights Only)** to normal operating condition.

OPERATING INSTRUCTIONS

Use these instructions for normal operations.

⚠ WARNING

Before operating the vehicle restraint, read and follow the Safety Practices, Warnings, and Operating Instructions in this manual. Use by untrained people could result in death or serious injury.

*Do not load or unload any vehicle unless you make certain the vehicle restraint has securely engaged the vehicle's RIG (rear impact guard) bar and set the brakes. If the vehicle restraint does not engage the RIG bar for any reason, **BE CERTAIN TO CHOCK THE VEHICLE WHEELS AND SET THE BRAKES BEFORE LOADING OR UNLOADING.***

Enter the vehicle only when the GREEN signal light on the control box is on. You must check the GREEN signal light every time the vehicle is entered, if the GREEN light goes out at any time during loading or unloading operations, immediately check the vehicle restraint to ensure that it is securely hitched. Vehicles leaving or moving when loading and unloading are in process could result in death or serious injury. Failure to place the hook in the stored position when not in use could result in damage to the vehicle restraint and incoming vehicles. Be certain bystanders in the driveway stand clear when the vehicle restraint is operated.

ENGAGING VEHICLE

1. When the vehicle restraint is stored, the outside GREEN light and inside RED lights will be on. See Fig. 19.
2. To secure the vehicle at the dock, press the **ENGAGE** button. The outside lights immediately change from GREEN to RED. The restraining hook will begin to raise. See Fig. 20.
3. The restraining hook will raise until it contacts the RIG of the vehicle. When the restraint has fully engaged the RIG bar, the inside lights will change from RED to GREEN. Visually check that the hooks have engaged the RIG bar to ensure that the vehicle is now safe to load or unload. See Fig. 21.

Fig. 19

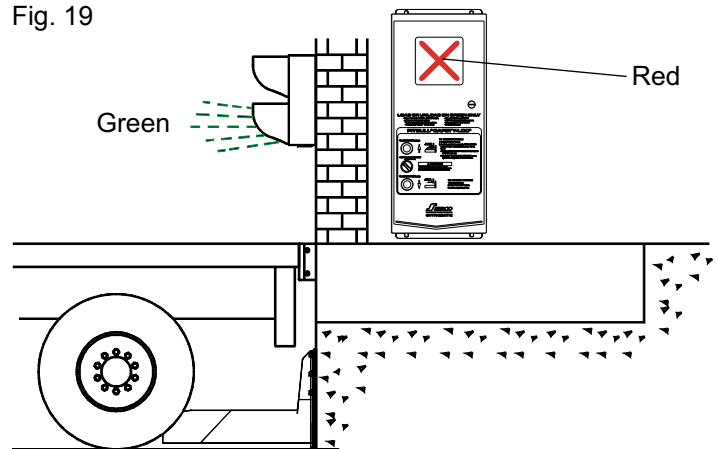

Fig. 20

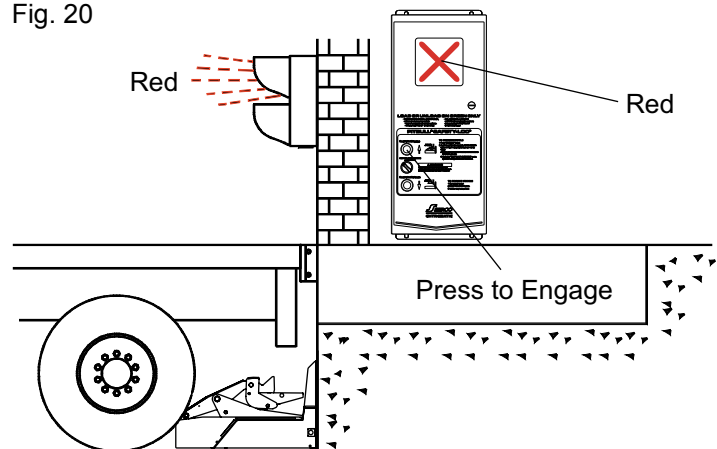
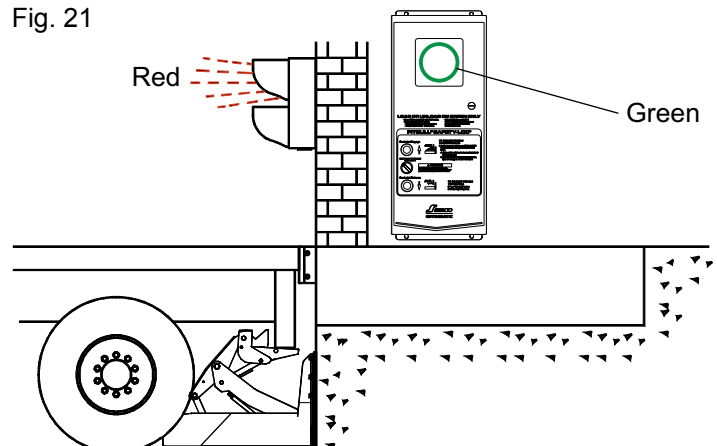

Fig. 21



OPERATING INSTRUCTIONS, continued

RELEASING VEHICLE

1. Store dock leveler.
2. To release the vehicle from the dock, press the **RELEASE** button. The inside lights immediately change from GREEN to RED. The restraining hook will lower until it is stored. The outside lights will change from RED to GREEN. See Fig. 22.

NOTE:

If optional LS5 leveler stored switch is installed the leveler must be stored before restraint will release.

⚠ WARNING

Do not initiate RESTRAINT OVERRIDE (LIGHTS ONLY) unless vehicle wheels have been chocked. Only authorized trained personnel should initiate RESTRAINT OVERRIDE (LIGHTS ONLY).

NO RIG (Rear Impact Guard)

1. If the hook raises without making contact with the RIG, it will lower to the stored position. At this time the inside RED and AMBER lights will flash indicating that the vehicle could not be secured. Chock the wheels, and then turn the selector switch to the **RESTRAINT OVERRIDE (Lights Only)** position. The outside lights change from GREEN to RED, the inside lights change to GREEN and AMBER. The vehicle is now safe to load or unload. When loading is completed, remove the wheel chocks and press the **RELEASE** button to return to the normal operation. The inside lights change to RED and the outside lights change to GREEN. See Fig. 23.

HIGH RIG (Rear Impact Guard)

1. If during unloading, the vehicle raises and the restraint hook loses contact with the RIG, the inside light will change from GREEN to RED and flashing AMBER to indicate a possible safety hazard. The restraint will remain in the raised position. Chock the wheels and then turn the selector switch to **RESTRAINT OVERRIDE (Lights Only)**. When loading is completed, remove the wheel chocks and press the **RELEASE** button to return to the normal operation. See Fig. 24.

Fig. 22

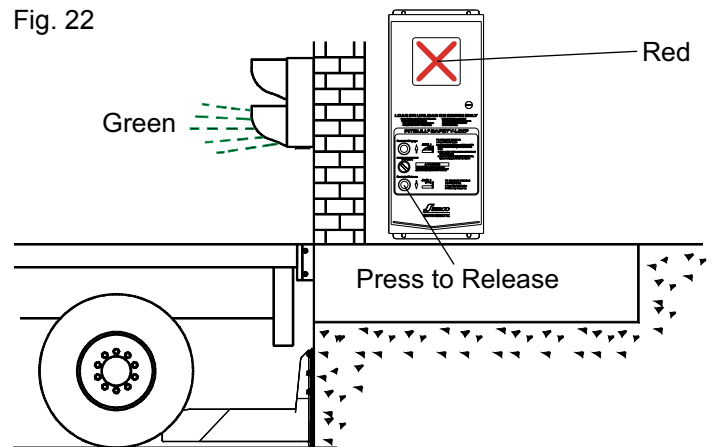

Fig. 23

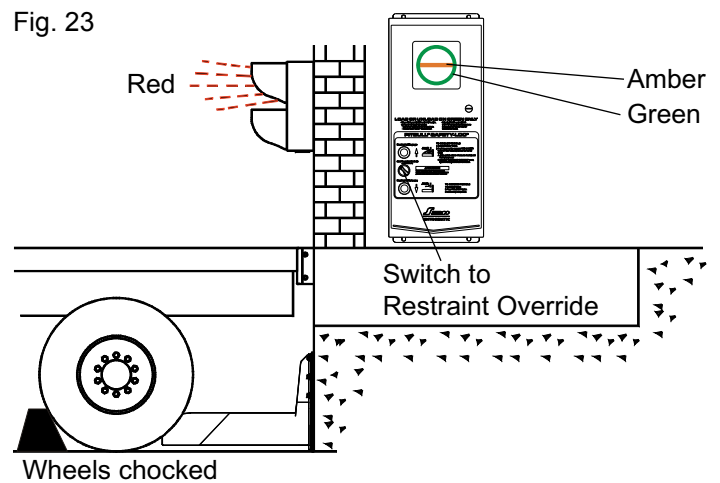
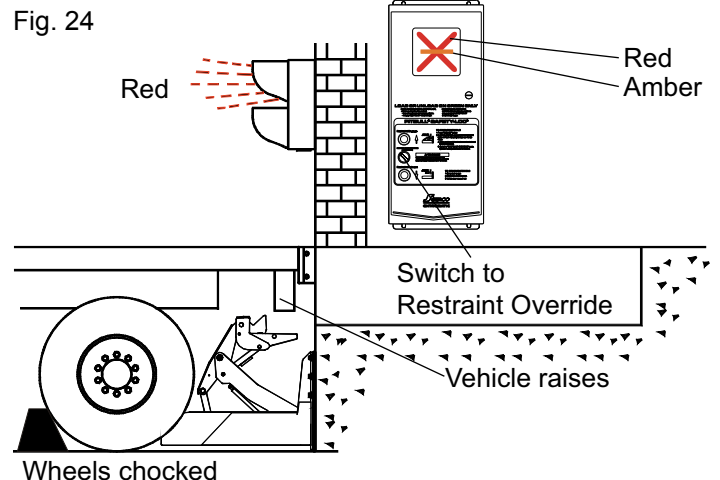

Fig. 24



PLANNED MAINTENANCE

WARNING

Before servicing the vehicle restraint, read and follow the Safety Practices on page 3 and the Operation section in this manual. Failure to do so could result in death or serious injury.

To ensure the continued proper operation of your vehicle restraint, perform the following planned maintenance procedures.

DAILY

1. Check all lights on the control panel and outside to ensure they are functioning.
2. Inspect dock bumpers. Missing bumpers must be replaced.

WEEKLY

1. Remove all debris from the vehicle restraint to ensure operation is unobstructed.
2. Inspect operation of the RIG sensor bar to ensure it pivots freely.
3. Inspect the vehicle restraint for damage that may weaken the anchoring strength. Re-tighten the concrete anchors if necessary.

QUARTERLY





1. Remove the side cover of the restraint and remove any debris.
2. Inspect the proximity sensors for proper adjustment. Refer to pages 31-34.
3. Lubricate and clean as shown in Fig. 25 on page 22.
4. Raise the restraint and inspect the mechanism for any signs of wear, distortion or cracked welds.
5. Check all operating, warning, and caution labels and signs and be sure they can be read. Replace as necessary.
6. Inspect operation of the RIG sensor bar to ensure it pivots freely.
7. Inspect the vehicle restraint for damage that may weaken the anchoring strength. Re-tighten the concrete anchors if necessary.
8. Inspect all mechanical pivot points on the restraint. If necessary clean and remove foreign material with brush and penetrating oil.
9. Inspect dock bumpers. Four inches (4") of projection is required. Worn, torn, loose or missing bumpers must be replaced.

PLANNED MAINTENANCE, continued

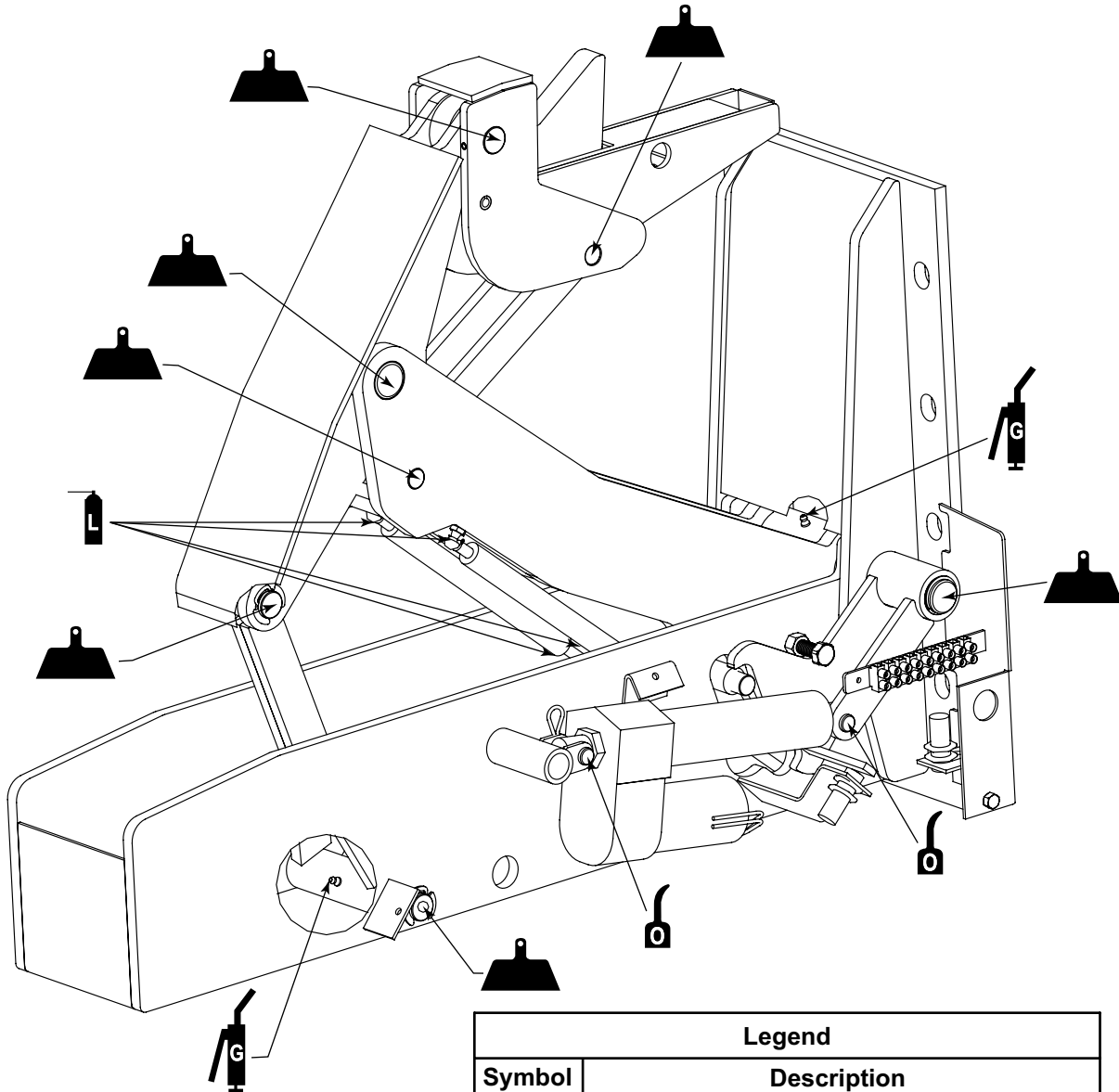
LUBRICATION

Fig. 25



Legend	
Symbol	Description
	Lubricate actuator pivot pins with SAE 30W oil.
	Lubricate main arm pin and front strut pin with bearing grease. Apply at grease zerk.
	Lubricate gas spring ball studs with spray type lithium grease (both ends).
	Clean and remove foreign material from all pivot points using a brush and penetrating oil.

TROUBLESHOOTING GUIDE

⚠ WARNING

Before servicing the vehicle restraint, read and follow the Safety Practices on page 3 and the Operation section in this manual. Failure to do so could result in death or serious injury.

The functions of the vehicle restraint are controlled by a Programmable Logic Controller (PLC) which has LED indicator lights to display errors and the state of input and output signals. For PLC LED diagnostics please refer to pages 26-30 in this manual.

Use the Troubleshooting Guide if the vehicle restraint fails to perform properly. Find the condition that most closely matches your situation, and make the recommended adjustments.

PROBLEM	POSSIBLE CAUSE	SOLUTION
1. No inside lights	<ul style="list-style-type: none"> a) FU225 failed. b) Power supply (PLC224) damaged or short circuited. c) Missing supply leads at terminals UP ZP on PLC203. d) Are one or more of the PLC stats LEDs Y0, Y1, Y2 illuminated. 	<ul style="list-style-type: none"> a) Check and replace fuse. b) Check for 24V DC on power supply output - If no voltage disconnect wires on 24V and 0V terminals and recheck voltage - No voltage replace power supply. c) Verify wiring to these terminals and check for 24V DC between ZP and UP. If no voltage present, check the continuity of the wires between the power supply and terminals UP and ZP. Correct connection issue if there is no continuity. d) YES <ul style="list-style-type: none"> 1. Missing or damaged wires to inside light element. 2. Inside Light unit has failed. NO <ul style="list-style-type: none"> 1. Check for PLC power indicator, should be illuminated and green. 2. Verify or put PLC RUN switch in the RUN position. See Fig. 27. 3. Review system error codes on page 30. 4. Validate software version (contact factory).

TROUBLESHOOTING GUIDE, continued

PROBLEM	POSSIBLE CAUSE	SOLUTION
2. No outside light(s).	<p>a) FU225 failed.</p> <p>b) Power supply (PLC224) damaged or short circuited.</p> <p>c) Flasher (DV226) failed or missing.</p> <p>d) Missing or damaged field connections at terminals OC, OR or OG.</p> <p>e) Outside light element (LT224) failed.</p>	<p>a) Check and replace fuse check for 24V DC on power supply output - If no voltage disconnect wires on 24V and 0V terminals and recheck voltage -</p> <p>b) No voltage replace power supply.</p> <p>c) Flasher can be replaced by a jumper to verify outside light operation temporarily.</p> <p>d) Verify wiring is correct and terminations are good.</p> <p>e) Replace outside light element(s).</p>
3. Outside light always red.	<p>a) OSL control relay (CR237) not energizing. Does PLC status LED Y3 illuminate?</p>	<p>a) YES 1. Missing or damaged wiring to terminals A1 or A2.</p> <p>NO 1. Restraint not fully stored.</p>
4. Interlock relay (CR233) OFF.	<p>a) Does PLC status LED Y2 illuminate?</p>	<p>a) YES 1. Check ISG control relay (CR233).</p> <p>NO 1. Establish proper conditions for interlock.</p>
5. Diagnostic code 2 (LS4 on while restraint is fully lowered).	<p>a) Amber light segment is displaying a 2-flash amber light pattern.</p>	<p>a) 1. ICC sensor bar stuck or in a bind. 2. Pinched LS4 cable. 3. Damaged LS4 sensor.</p>

TROUBLESHOOTING GUIDE, continued

PROBLEM	POSSIBLE CAUSE	SOLUTION
6. Diagnostic code 3 (Raise timeout: Failure to detect LS2 while fully raised).	a) Amber light segment is displaying a 3-flash light pattern.	a) <ol style="list-style-type: none"> 1. LS2 damaged, misadjusted or disconnected. 2. LS2 Target damaged. 3. Sector plate is bound. 4. Severed or disconnected LS2 sensor cable. 5. Linear actuator motor not running (see troubleshooting item 10).
7. Diagnostic code 4 (Lower Timeout: Failure to detect LS1 while fully lowered) This failure will put the system into JOG mode.	a) Amber light segment is displaying a 4-flash pattern.	a) <ol style="list-style-type: none"> 1. Hook arm is blocked by debris or bound. 2. LS1 damaged, misadjusted, or disconnected. 3. LS1 target damaged. 4. Severed or disconnected LS1 sensor cable. 5. Linear actuator motor not running (see troubleshooting item 10).
8. Diagnostic code 5 (LS1 and LS2 are both on at the same time). 8. Diagnostic code 5 (LS1 and LS2 are both on at the same time).	a) Amber light segment is displaying a 5-flash pattern.	a) YES <ol style="list-style-type: none"> 1. Check ISG control Relay (CR233). NO <ol style="list-style-type: none"> 1. Establish proper conditions for interlock.
9. Diagnostic Code 6 (Flood).	a) Amber light segment is displaying a 6-segment pattern.	a) Pinched sensor cables.
10. Linear actuator motor not operating.	a) Actuator not running.	a) <ol style="list-style-type: none"> 1. Check 15 amp fuse located on the MOD231 relay board. 2. Verify actuator wiring does not have issues. 3. Check Mod231 board to verify voltage going to the actuator. 4. With power to the actuator, and it does not run, replace the actuator.

PLC DIAGNOSTICS

WARNING

Do not service this product unless you have read and followed the Safety Practices, Warnings, and Operating Instructions in this manual. Failure to follow these safety practices could result in death or serious injury.

WARNING

Keep hands and feet away from the restraint when in JOG Mode. Operation may return as soon as the fault is cleared. Failure to keep clear could result in death or serious injury.

CONTROL PANEL – LED DISPLAY

The vehicle restraint is controlled by a solid state Programmable Logic Controller (PLC) which reads input signals from the pushbuttons and proximity sensors, and closes the appropriate output relays to the motor and to the warning lights.

INPUT SIGNALS

- 0 - Restraint override switch
- 1 - LS1 lowered proximity switch (normally closed)
- 2 - LS2 raised proximity switch
- 3 - Unused Input
- 4 - LS4 RIG sensor bar
- 5 - Flood
- 6 - Engage pushbutton
- 7 - Release pushbutton

OUTPUT FUNCTIONS

- 0 - Red light - panel face
- 1 - Amber light - panel face
- 2 - Green light - panel face
- 3 - Exterior light relay (RED = off)
- 4 - Restraint engaged
- 5 - Restraint released

PLC DIAGNOSTICS, continued



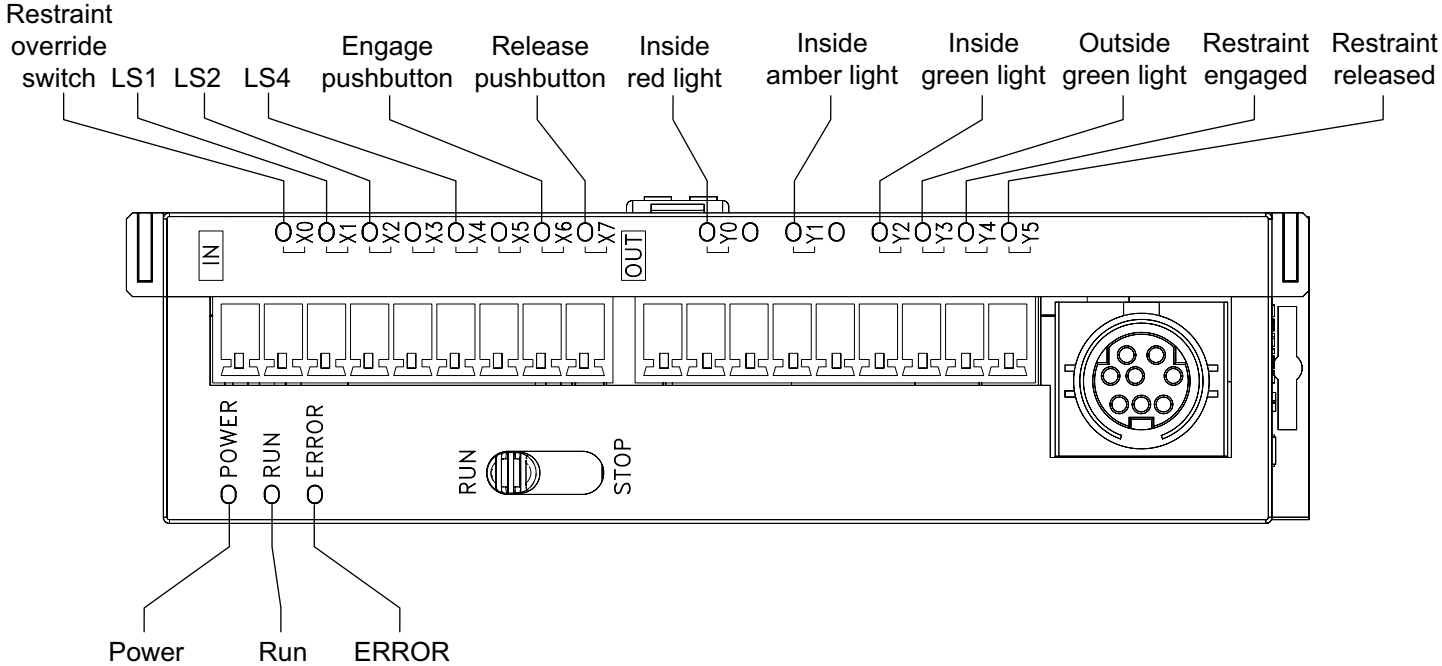

The face of the PLC has LED indicator lights which show the status of each input and output. The ERROR LED will indicate when an error condition exists. See page 30 for ERROR conditions

Fig. 26



PLC DIAGNOSTICS, continued

The charts below shows all of the valid conditions for the standard unit in normal operation.

 LED On
  Button Pressed
  LED Off
  LED Flashing

RESTRAINT STORED

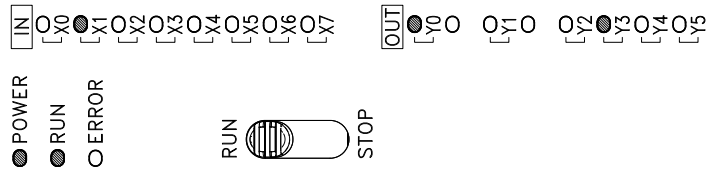

ENGAGE (raising)

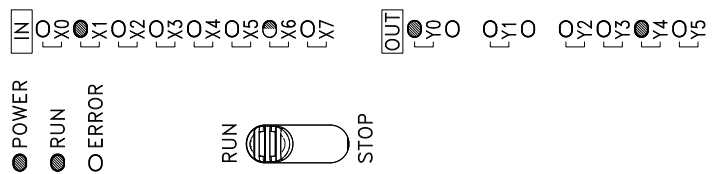

HITCHED

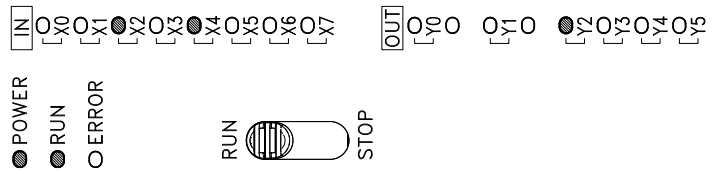



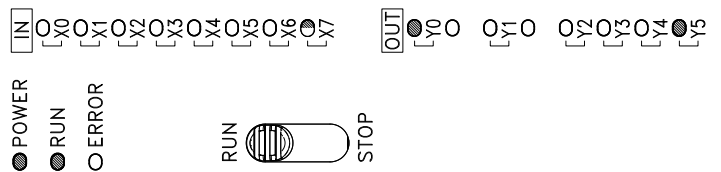

RELEASE (lowering)



PLC DIAGNOSTICS, continued

The charts below shows all of the valid conditions for the standard unit in normal operation.

 LED On
  Button Pressed
  LED Off
  LED Flashing

MISSED HITCH (stored)

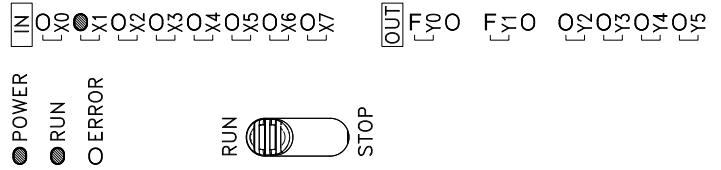

OVERRIDE (stored)

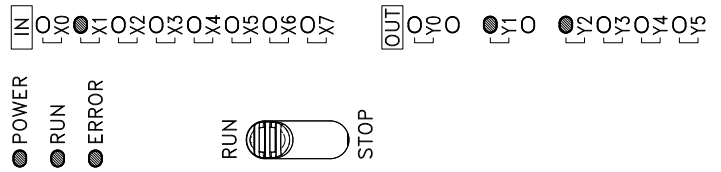

FAULT (diagnostic)

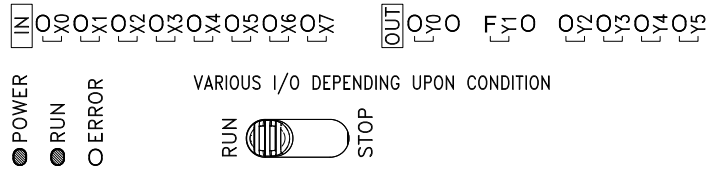

PLC DIAGNOSTICS, continued

SYSTEM ERRORS

“ERROR” LED

Slow Blink: Program corruption. Additional information regarding the error can be found in special data register D1004.

Fast Blink: 24VDC power is low.

Solid: Execution time exceeded (runtime error). See D1000. Excessive noise or a hardware problem inside the PLC may also cause a persistent solid indication.

PLC LEGEND

Fig. 27

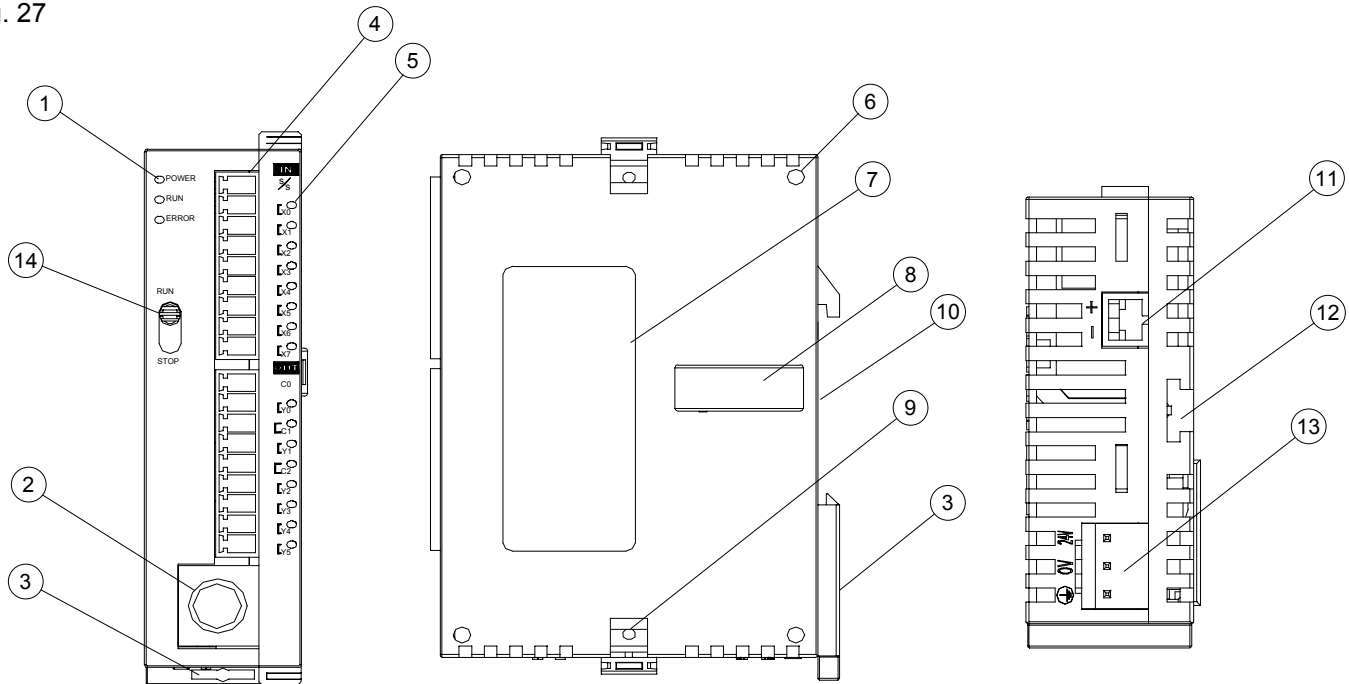

1. Status indicator (POWER, RUN AND ERROR)
2. I/O port for program communication (RS-232)
3. Din rail clip
4. I/O terminals
5. I/O point indicator
6. Mounting hole of the extension unit
7. Nameplate

8. Extension port
9. Extension unit clip
10. Din rail (35mm)
11. RS-485 communication port
12. Mounting rail of the extension unit
13. DC power input
14. Run/stop switch

ADJUSTMENTS

Use these instructions to adjust the vehicle restraint.

PROXIMITY SENSOR LOCATIONS

Three proximity sensors are used to sense the various positions of the vehicle restraint. The sensors are solid state proximity devices which close the electrical circuit when they sense the presence of a steel target. The locations of these sensors are shown below. LS1 and LS2 sensors are located within slotted holes for variable positioning. Adjust the position of the proximity sensors using two 15/16" open end wrenches to loosen the holding nuts. Then slide the proximity sensor towards the front or back of the slot and gently tighten the nuts to 3.7 ft. lb to secure the sensor. The face of the proximity sensor must be between 1/16" - 1/8" from the target plate without making contact.

⚠ WARNING

Do not service this product unless you have read and followed the Safety Practices, Warnings, and Operating Instructions in this manual. Failure to follow these safety practices could result in death or serious injury.

Place barricades around the pit on dock floor and drive while installing, maintaining or repairing dock leveler or the vehicle restraint.

Keep hands and feet away from moving parts when making adjustments.

Fig. 28

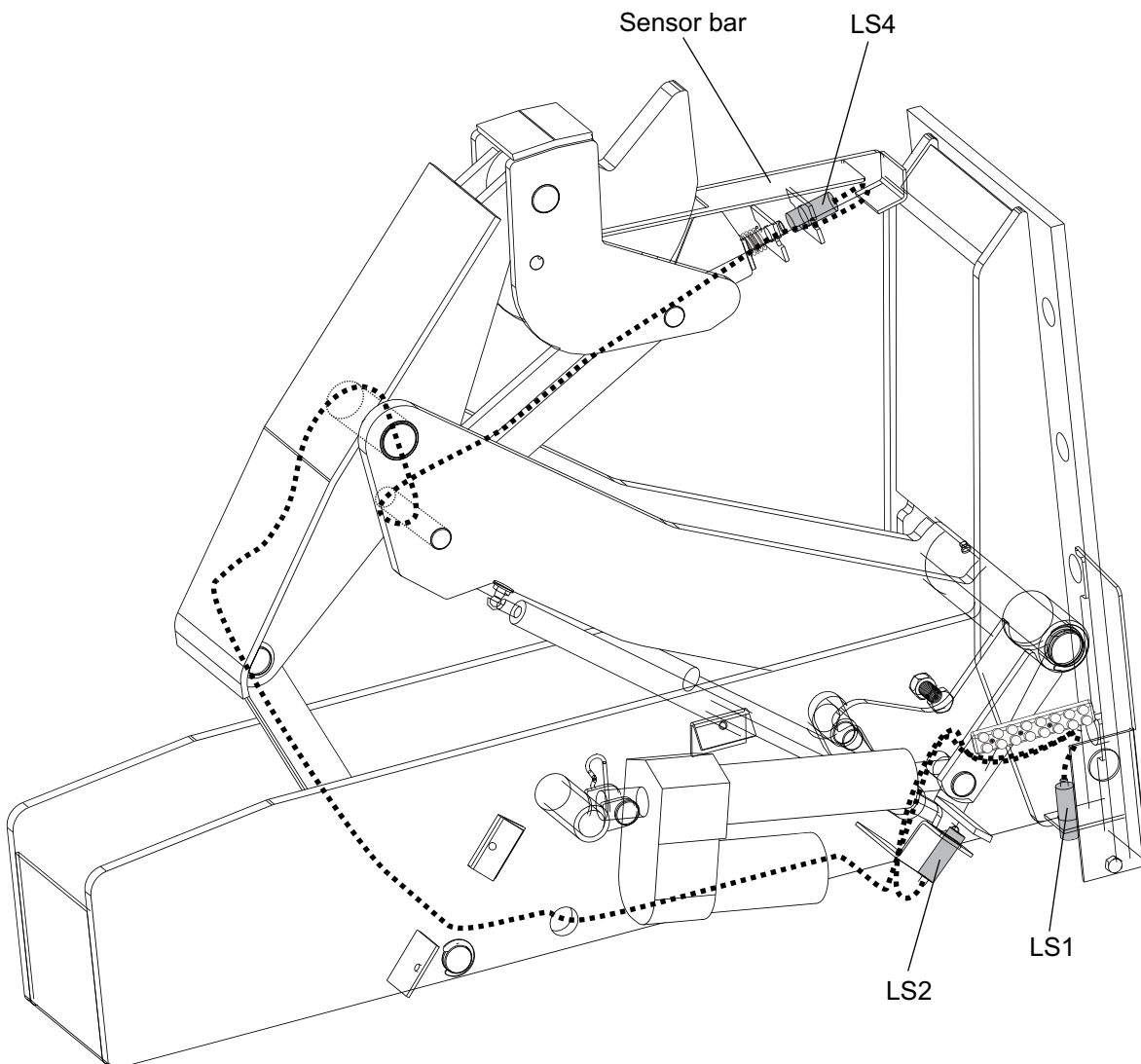

ADJUSTMENTS, continued

RESTRAINT STORED SENSOR – LS1

Proximity sensor LS1 controls the lowered position of the restraining hook by stopping the motor when the restraint is lowered. The correct stored position is when the top of the primary hook is approx. 3/16" below the frame housing. Equally important, when the restraint is stored there must be some slight movement felt when you push down on the top of the primary hook. To adjust proximity sensor LS1:

1. Raise the restraint and disconnect power.
2. Remove side cover.
3. Loosen nuts holding LS1.
4. Move proximity sensor backward in the slot to lower the stored position.
5. Move proximity sensor forward in the slot to raise the stored position.

6. Tighten nuts.
7. Reconnect power to the restraint. Return the restraint to the stored position. If the stored position is not correct, repeat steps 1-7.
8. Reinstall side cover.

If the actuator clutch slips and makes a ratcheting sound when the restraint is lowered, the proximity sensor LS1 is not closing. Move the sensor forward slightly and check the operation again.

NOTE:

Proper torque specification for tightening LS1 is 3.7ft lb.

Fig. 29

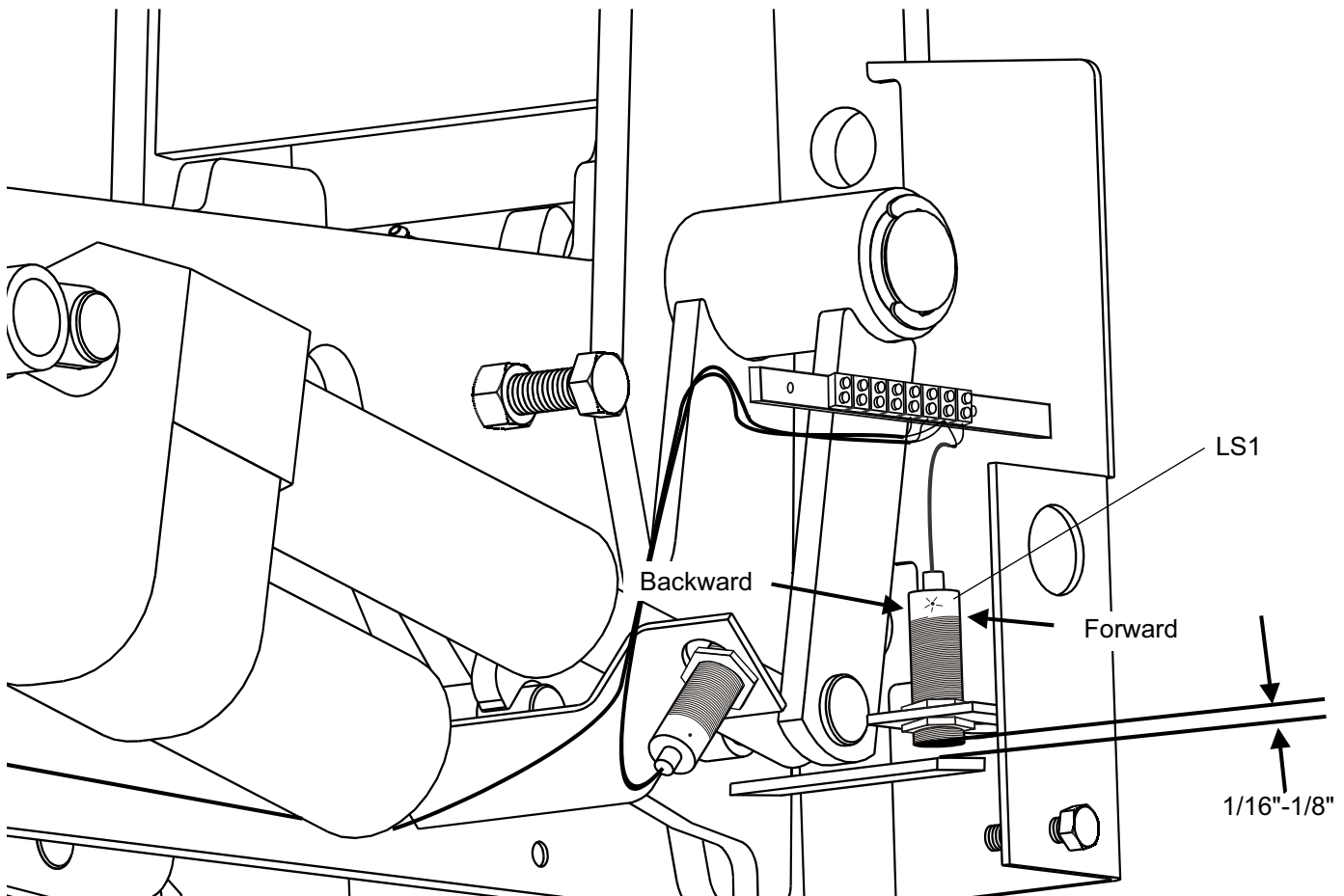

RESTRAINT RAISED SENSOR – LS2

Proximity sensor LS2 shuts off power to the linear actuator when the sector plate is fully raised and resting against the 1/2" stop bolt that acts as a physical limit for sector plate travel (see Fig. 30). To check the proper setting, press the engage button. As the restraint raises press and hold down the sensor bar turning on LS4 (RIG sensor). LS2 is properly adjusted if the linear actuator shuts off without ratcheting and the restraint reaches its fully raised height with sector plate resting on the 1/2" stop bolt.

NOTE:

Proper torque specification for tightening LS2 is 3.7ft lb.

TO ADJUST THE PROXIMITY SENSOR LS2:

1. Remove side cover of restraint.
2. Disconnect proximity sensor LS2 on the terminal strip. See Fig. 13 on page 13.
3. Raise restraint until the linear actuator ratchets with the sector plate resting against the 1/2" stop bolt, then turn off power to the restraint.
4. Loosen sensor retaining nuts holding LS2.
5. Move proximity sensor until it is centered on the sector plate sensor target and the face of the sensor is 1/16" - 1/8" away from the target (see Fig. 30 and 31).
6. Tighten retaining nuts.
7. Reconnect proximity sensor LS2 to the terminal strip. See Fig. 13 on page 13.
8. Turn on power to restraint and lower unit by pressing the **RELEASE** button.
9. Raise the restraint and verify the setting. Repeat steps 2 through 9 if required.
10. Reinstall side cover.

Fig. 30

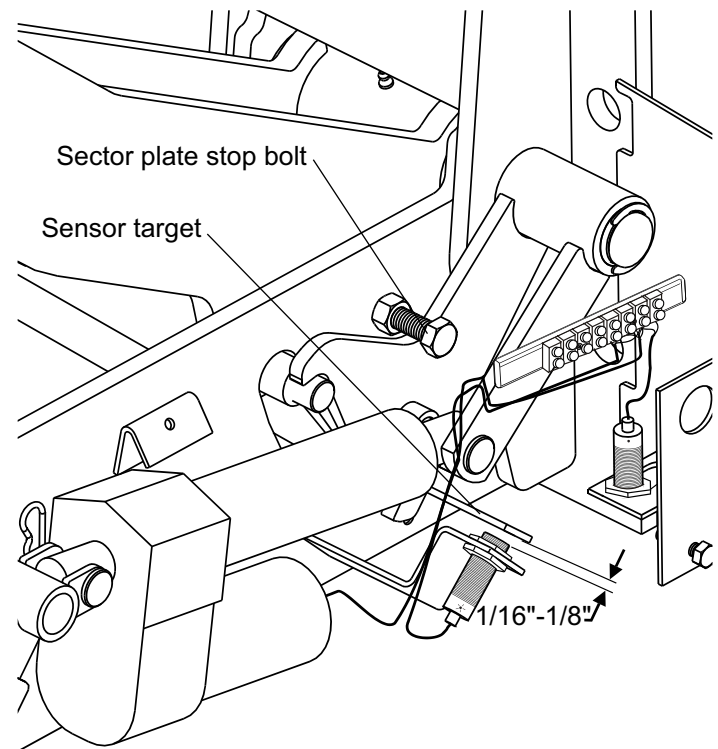
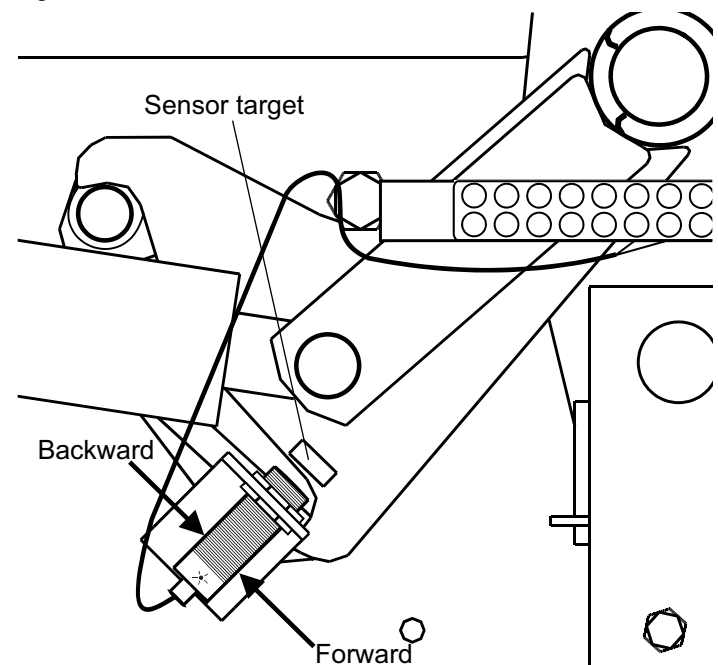

Fig. 31



ADJUSTMENTS, continued

RIG SENSOR BAR – LS4

Proximity sensor LS4 senses when the restraining hook has contacted an RIG. LS4 is properly adjusted if the flashing AMBER light turns off when the restraint is raised and the sensor bar is depressed.

Raise the restraint and press down on the sensor bar before the motor stops. The restraint will remain raised. Releasing the sensor bar will cause the AMBER light to flash.

The proper setting of LS4 is 1/16"-1/8" between sensor target and proximity sensor while the sensor bar is depressed.

NOTE:

Proper torque specification for tightening LS4 is 3.7ft lb

To adjust LS4, order the special tool from your local Serco Entrematic distributor. P/N: **AP2632 - VEHICLE RESTRAINT LS4 15/16" WRENCH SET** or make your own tool using the following instructions:

1. Buy a 15/16" combination wrench (one end open-end, other end 12-point box)
2. Using an abrasive cutoff wheel or "chop saw", cut the wrench in half, in the middle of the handle.
3. Carefully remove a 0.708" - 0.750" section from the box "ring", directly opposite the handle. This is important, as the wrench must pass over the 18mm body of the proximity sensor.
4. Sand any sharp edges or burrs.

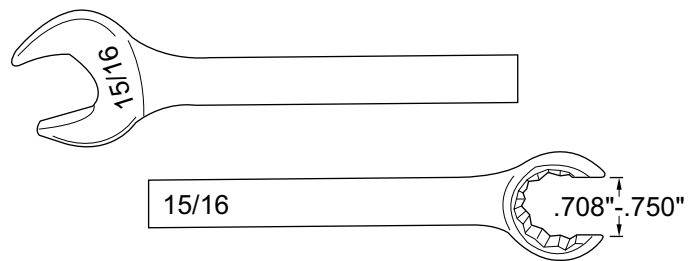
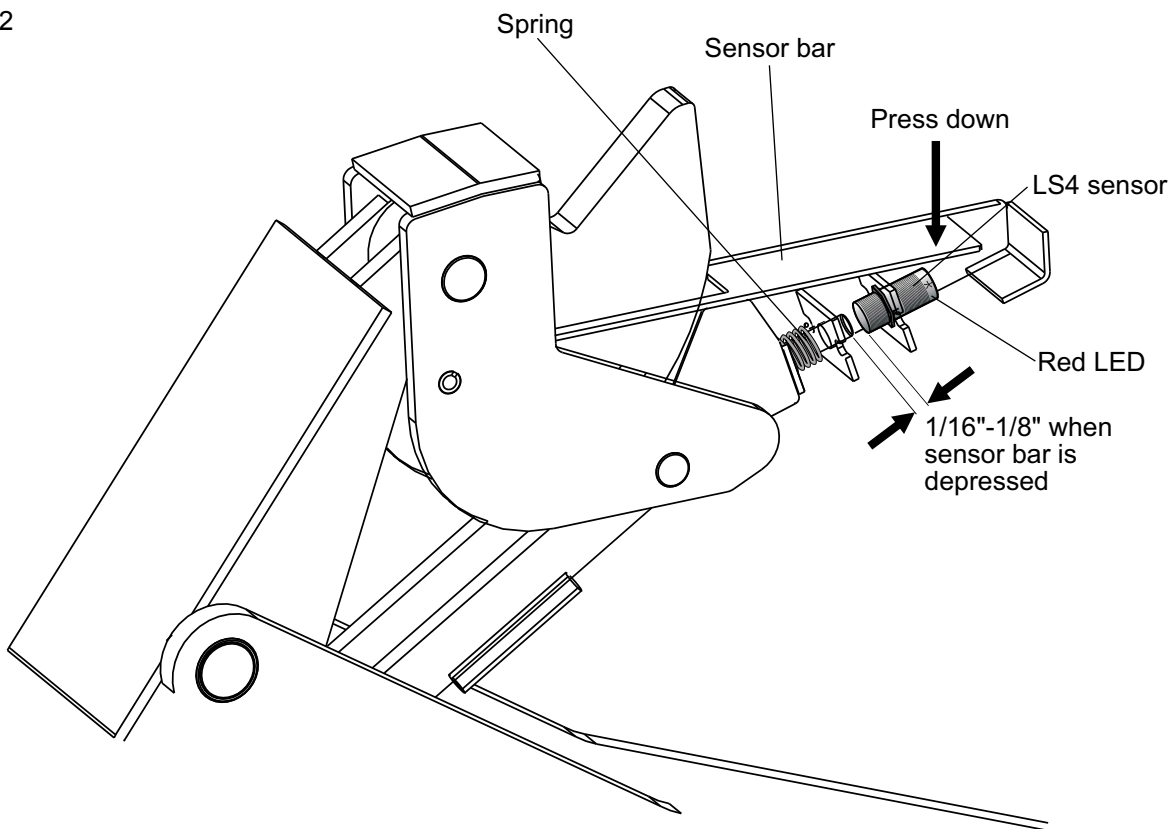

Fig. 32



GAS SPRING REPLACEMENT

TO REPLACE GAS SPRINGS ON THE PITBULL® SAFETY-LOC® SERIES RESTRAINT

Two gas springs are used on the PitBull® SAFETY-LOC® series restraints to bias the moving parts upward. Gas springs contain high pressure compressed nitrogen, and must be handled with care. The gas springs are charged with approx. 200 lbs. of force, and must BOTH be changed if either gas spring weakens or is damaged. To successfully replace gas springs, you must follow the instructions below.

1. Remove the side cover from the restraint with the restraint in the lowered position.
2. Remove the sector plate stop bolt.
3. Disconnect proximity sensor LS2 on the terminal strip. See Fig. 13 on page 13.
4. Push the **ENGAGE** button to raise the restraint. When the hook reaches the top of the stroke and begins to make a 'ratcheting' sound you must turn off the power.
5. Disconnect the **ORANGE** wire from the motor side of the terminal strip on the restraint. Insulate the bare end of this wire with a 'wire-nut' or electrical tape. This will make it impossible to lower the restraint electrically while you are working on it.
6. Cut a piece of 2x4 lumber to length and fit it tightly between the frame and the underside of the main arm. See Fig. 33. The length of this 2x4 must allow the gas springs to reach their free length.

WARNING

The moving parts of the restraint are very heavy, and are supported by the gas springs. Great care must be taken to support the weight of these parts while removing or replacing the gas springs.

7. Remove the klipring from one end of the pin that joins the front strut assembly to the upper arm assembly. Carefully slide out the pin while replacing it with a 1/4" diameter shaft screwdriver. This will allow the gas springs to extend to their free length so that they can be removed.

NOTE:

You may have to use the supporting wood to force the main arm assembly upwards even further than before you removed the pin.

8. Replace the gas springs one at a time beginning with the most obviously damaged gas spring. This may help to counterbalance some of the weight while you are working on the unit. Place a small dab of grease in each ball socket before you push the socket onto the ball stud. Make sure the rod end of the gas spring points downward.

GAS SPRING REPLACEMENT, continued

NOTE:

Make sure the ball sockets are properly aligned – hold the gas spring in your hand and using pliers tighten the barrel end socket snug. Next hold the barrel in your hand as you use pliers on the rod end ball socket. Rotate the rod clockwise as you index the rod to proper orientation.

NOTICE

Do NOT use pliers on the chrome rod surface!

9. With both gas springs installed and the retainer clips in place, you can remove the 2x4 support, replace the front strut pin and kliprings.
10. Reconnect the ORANGE motor wire, and the LS2 wire to the appropriate terminal strip connections. Install the sector plate stop bolt. Turn the power on and push the **RELEASE** button to restore the restraint.
11. Test the unit and reinstall the side cover.

Fig. 33

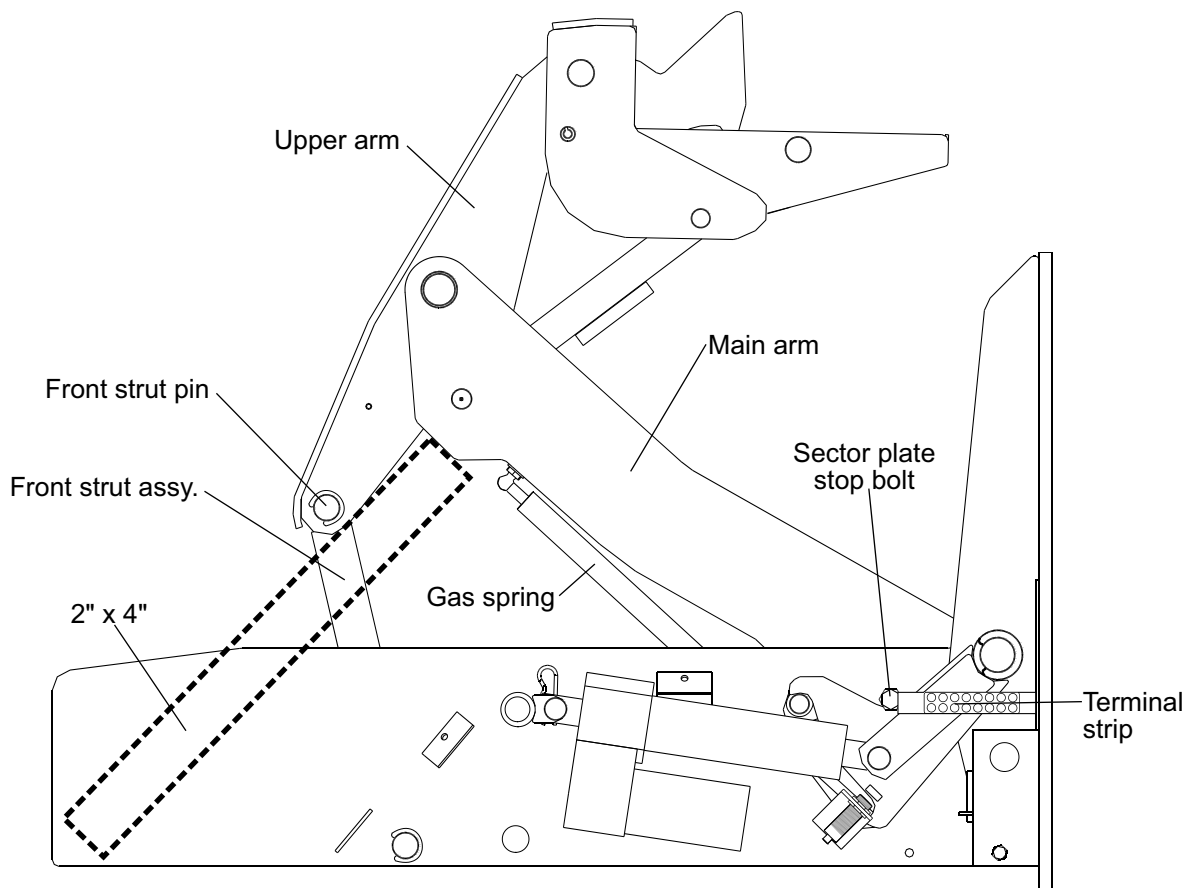

PARTS LIST — VEHICLE RESTRAINT

⚠ WARNING

To ensure proper function, durability and safety of the product, only replacement parts that do not interfere with the safe, normal operation of the product must be used. Incorporation of replacement parts or modifications that weaken the structural integrity of the product, or in a way alter the product from its normal working condition at the time of purchase from Serco Entrematic could result in product malfunction, breakdown, premature wear, death or serious injury.

Fig. 35

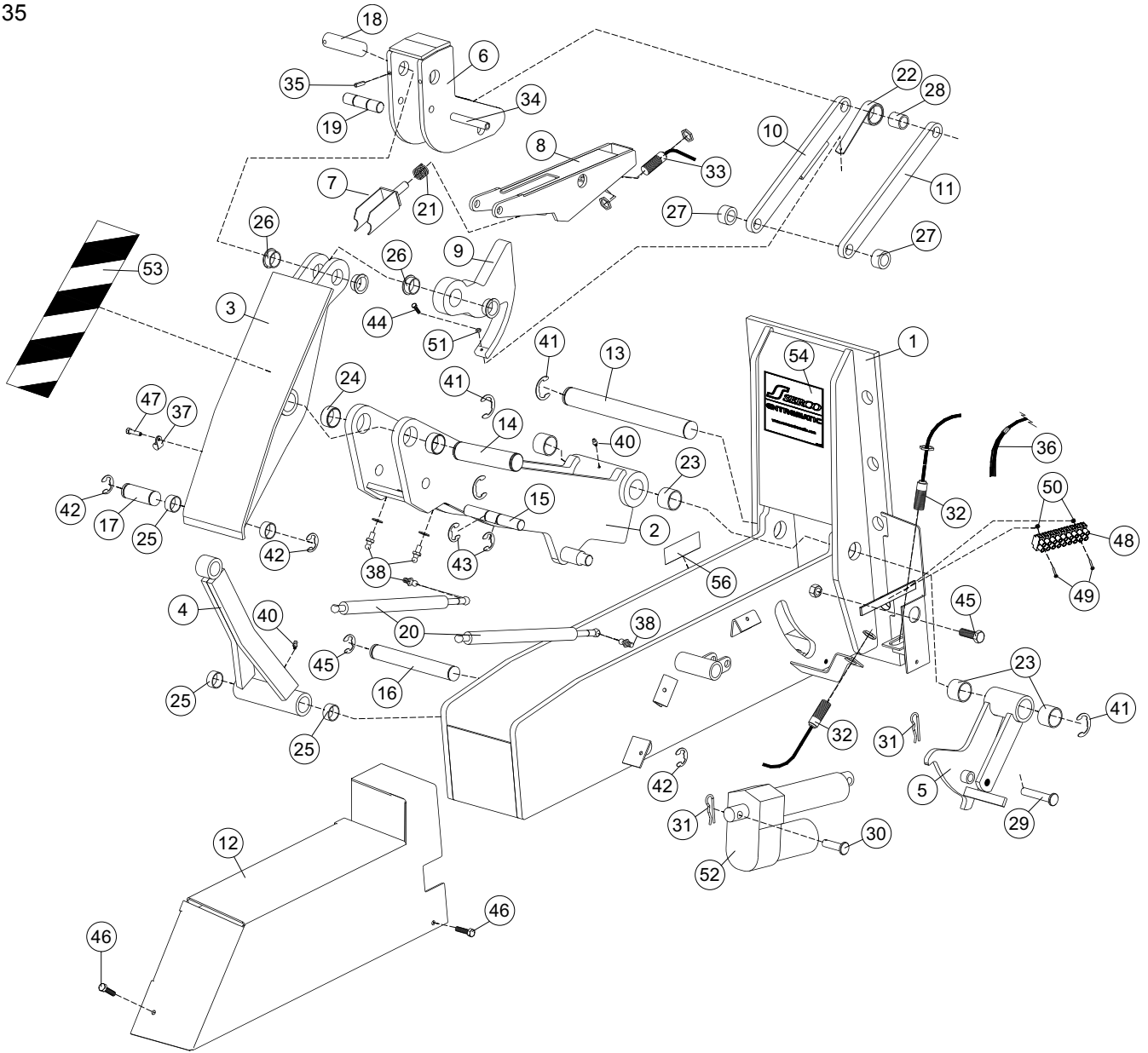

PARTS LIST — VEHICLE RESTRAINT, continued

Item	Quantity	Part Description	Part Number
1	1	FRAME ASSEMBLY, INCLUDES ITEMS 38 AND 45	90001
2	1	MAIN ARM ASSEMBLY, INCLUDES ITEMS 23, 24, 38 AND 40	90003
3	1	UPPER ARM ASSEMBLY, INCLUDES ITEMS 25 AND 26	6001535
4	1	FRONT STRUT ASSEMBLY, INCLUDES ITEMS 25 AND 40	90007
5	1	SECTOR PLATE ASSEMBLY, INCLUDES ITEM 23	90009
6	1	PRIMARY HOOK ASSEMBLY	90011
7	1	SENSOR TARGET ASSEMBLY	90027
8	1	SENSOR BAR ASSEMBLY	90028
9	1	SECONDARY HOOK ASSEMBLY, INCLUDES ITEM 26	90015
10	1	HOOK STRUT ASSEMBLY	90030
11	1	HOOK STRUT	4850240
12	1	HOUSING COVER	90029
13	1	PIN - 1-1/4 OD	4850056
14	1	PIN, UPPER ARM-MAIN ARM, 1-1/4" OD, SL10-90	6001534
15	1	PIN-MAIN ARM, 3/4 OD	4850035
16	1	PIN-FRAME, 1" OD	4850038
17	1	PIN-FRONT STRUT, 1" OD	4850037
18	1	SL-PIN-PRIMARY HOOK, 1" DIA.	4850108
19	1	SL PRIMARY HOOK PIN, 1" DIA.	4850119
20	2	GAS SPRING	338018
21	1	SPRING (LS4)	333047
22	1	SPRING (CONSTANT FORCE)	338009
23	4	BUSHING - 1-1/4"	821032
24	2	BUSHING - 1-1/4"	821035
25	4	BUSHING - 1"	821034
26	4	BUSHING - 1" (FLANGE)	821033
27	2	SPACER - MAIN ARM	4850026
28	1	NYLON ROLLER	4850235
29	1	CLEVIS PIN - 1/2" DIA. X 2-3/4" LG.	231502
30	1	CLEVIS PIN - 1/2" DIA. X 1-25/32" LG.	231505
31	2	HITCH PIN CLIP	231503
32	2	LS1, LS2 PROXIMITY SWITCH (C/W HARDWARE)	625036
33	1	LS4 PROXIMITY SWITCH (C/W HARDWARE) 18MM - LOW TEMP	625043

PARTS LIST — VEHICLE RESTRAINT, continued

Item	Quantity	Part Description	Part Number
34	1	TENSION PIN - 1/2" DIA. X 3-1/4" LG.	231205
35	1	TENSION PIN - 1/4" DIA. X 3/4" LG.	231128
36	1	SL60 WIRING HARNESS KIT	99855
37	1	CABLE CLIP	441125
38	4	BALL STUD	821037
39	N/S	HEATER KIT (OPTIONAL) INSTALLS ON RESTRAINT	99726
40	2	GREASE FITTING (C/W BALL CHECK)	417113
41	4	CRESRING - 1-1/4"	236123
42	4	KLIPRING - 1"	236114
43	2	KLIPRING - 3/4"	236110
44	1	HHMS 10-32 X 3/4" LG.	211820
45	1	HHMB 1/2-13 X 1-1/2" LG.	212204
46	2	HH-STS 5/16-18 X 1/2" LG.	216460
47	1	TEKS-4 SCREW 12-24 X 7/8	6000285

PARTS LIST — VEHICLE RESTRAINT, continued

Item	Quantity	Part Description	Part Number
48	1	TERMINAL BLOCK - 9 POLE	6013766
49	2	RHMS 4-40 UNC X 3/4" LG	6013767
50	2	LOCK NUT 4-40 NYLON INSERT	6013768
51	1	LN 10-32 NYLOCK	214123
52	1	LINEAR ACTUATOR	341008
53	1	HAZARD STRIPE	6008556
54	1	PRODUCT IDENTIFIER LABEL SL	921185
55	1	TRAILER PRESENT SENSOR KIT (OPTIONAL - NOT SHOWN)	99221
56	1	SERIAL TAG	6009761
57A	7	ANCHOR BOLT, 3/4 UNC X 5-1/2 (NOT SHOWN) (WALL MOUNT ONLY)	6001187
57B†	2	ANCHOR BOLT, 3/4 UNC X 7 (NOT SHOWN) GROUND MOUNT	6001334
58†	4	EPOXY ANCHOR ROD - 3/4 RAWL (NOT SHOWN)	235406
59†	4	EPOXY CAPSULE - 3/4, RAWL #65 (NOT SHOWN)	235407

† *Ground mount kit.*

PARTS LIST — CONTROL PANEL

6016000

Fig. 36

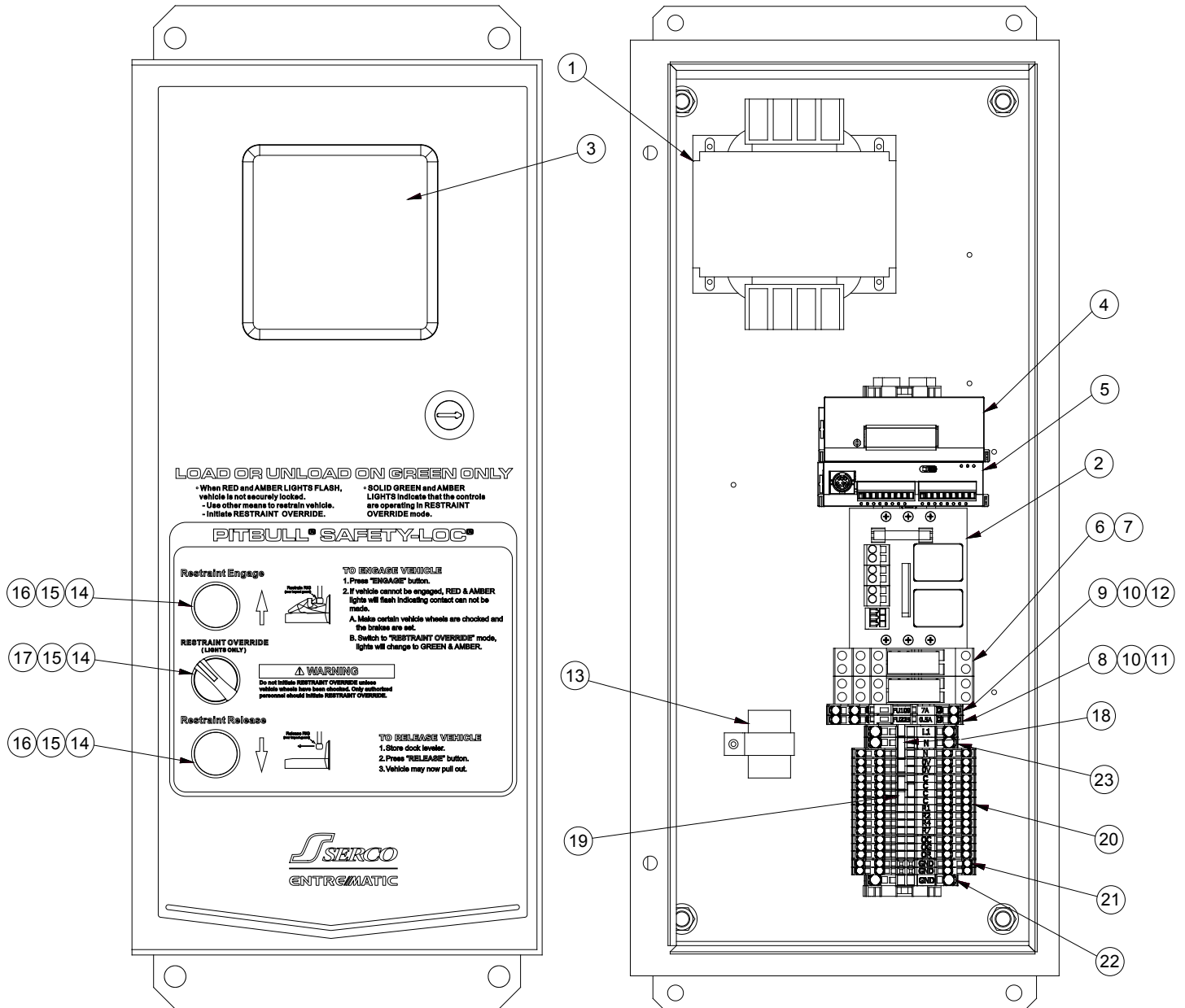

PARTS LIST — CONTROL PANEL, continued

6016000

Item	Quantity	Part Description	Part Number
1	1	XFMR, 120240V TO 24V, 350VA	6006811
2	1	LINEAR ACTUATOR RELAY BOARD	6018340
3	1	PANELFACE LIGHT MODULE, COMPOSITE, R/A/G/B, 24VDC	6018495
4	1	DVP POWER SUPPLY, 24 W, 1 AMP	6017904
5	1	DVP-SS2 PLC, 8 DC IN, 6 OUT NPN, SPRING CLAMP	6017898
6	2	RELAY, 2P, MINIATURE P.C.B, FROM C, 24VDC	6000520
7	2	SOCKET, RELAY, 40 SERIES	6000522
8	1	FUSE, TIME DELAY, GMC-500MA	6021207
9	1	FUSE, TIME DELAY, GMC-7A	6021215
10	2	CARRIER TERMINAL BLOCK, 3P, 5MM	6018475
11	2	FUSE PLUG WITH PULL-TAB	6018477
12	2	END PLATE, 3P, 1MM, ORANGE	6018476
13	1	FLASHER, 2 WIRE, 24VDC, 1A, 60FPM	6018502
14	3	BLOCK, CONTACT, N.O.	632-228
15	3	BODY, MOUNTING COLLAR	6000515
16	2	PUSH BUTTON, MOMENTARY, NEMA 4/4X/13	6000506
17	1	SELECTOR, 2 POS. SPRG RTN TO LEFT, NEMA 4/4X/13	632-219
18	1	JUMPER BAR, STEP-DOWN (2004 TO 2001)	6018478
19	5	JUMPER BAR, 2-WAY (2001)	6018480
20	14	TERMINAL, 4 POLE	6018481
21	2	TERMINAL, 4 POLE, GROUNDING	6018557
22	1	TERMINAL, 2 POLE, GROUNDING	6021218
23	2	TERMINAL, 2 POLE	6007888

PARTS LIST — EXTERIOR SIGNS AND LIGHTS

Fig. 37

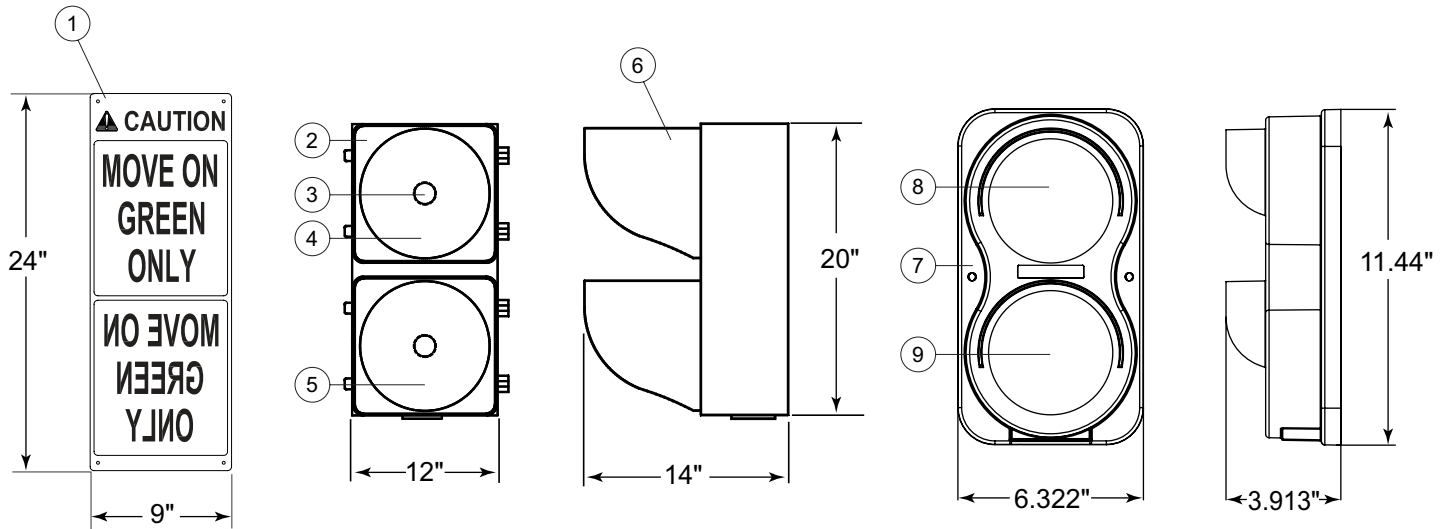

Item	Quantity	Part Description	Part Number
1	1	OUTSIDE SIGN - NORMAL LETTERING	709-832
2	1	LIGHT ASSEMBLY - COMPLETE (TRAFFIC LIGHTS)	8-9519
3*	2	LIGHT BULB 120V, 69 WATT	823-072
4*	1	LENS - RED	823-043
5*	1	LENS - GREEN	823-044
6*	2	VISOR	823-042
7	1	LIGHT ASSEMBLY - COMPLETE (LEDS) 24 VDC	6007798
8†	1	RED LED LIGHT ASSY. 24 VDC	6007800
9†	1	GREEN LED LIGHT ASSY. 24 VDC	6007801

* Part of Item 2 (Light Assembly – Complete).

† Part of Item 7 (Light Assembly – Complete).

LIMITED WARRANTY INFORMATION

THIS LIMITED WARRANTY IS SERCO ENTREMATIĆ'S SOLE AND EXCLUSIVE WARRANTY WITH RESPECT TO THE VEHICLE RESTRAINT AND IS IN LIEU OF ANY OTHER GUARANTEES OR WARRANTIES, EXPRESS OR IMPLIED.

Serco Entrematic warrants that this VEHICLE RESTRAINT will be free from flaws in material and workmanship under normal use for a period of one (1) year from the earlier of 1) 60 days after the date of initial shipment by Serco Entrematic, or 2) the date of installation of the VEHICLE RESTRAINT by the original purchaser, provided that the owner maintains and operates the VEHICLE RESTRAINT in accordance with this User's Manual.

In the event that this VEHICLE RESTRAINT proves deficient in material or workmanship within the applicable Limited Warranty period, owner shall so notify Serco Entrematic, and Serco Entrematic will, at its option:

1. Replace the VEHICLE RESTRAINT, or the deficient portion(s) thereof, without charge to the owner (excluding any cost of removal or reinstallation which shall be the sole responsibility of the owner); or
2. Alter or repair the VEHICLE RESTRAINT, on site or elsewhere, without charge to the owner.

This Limited Warranty does not cover any failure caused by improper installation, abuse, improper operation, negligence, or failure to maintain and adjust the VEHICLE RESTRAINT properly. Parts requiring replacement due to damage resulting from vehicle impact, abuse, or improper operation are not covered by this warranty. Serco Entrematic DISCLAIMS ANY RESPONSIBILITY OR LIABILITY FOR ANY LOSS OR DAMAGE OF ANY KIND (INCLUDING WITHOUT LIMITATION, DIRECT, INDIRECT, CONSEQUENTIAL OR PUNITIVE DAMAGES, OR LOST PROFITS OR LOST PRODUCTION) arising out of or related to the use, installation or maintenance of the VEHICLE RESTRAINT (including premature product wear, product failure, property damage or bodily injury resulting from use of unauthorized replacement parts or modification of the VEHICLE RESTRAINT). Serco Entrematic's sole obligation with regard to a VEHICLE RESTRAINT that is claimed to be deficient in material or workmanship shall be as set forth in this Limited Warranty. This Limited Warranty will be null and void if the original purchaser does not notify Serco Entrematic's warranty department within ninety (90) days after the product deficiency is discovered. .

THERE ARE NO WARRANTIES, EXPRESS OR IMPLIED, WHICH EXTEND BEYOND THE DESCRIPTION ON THE FACE HEREOF, INCLUDING, BUT NOT LIMITED TO, A WARRANTY OF MERCHANTABILITY OR OF FITNESS FOR A PARTICULAR PURPOSE, ALL OF WHICH SERCO ENTREMATIĆ HEREBY DISCLAIMS.

Please direct questions about your vehicle restraint to your local distributor or to Serco Entrematic Technical Service.

Your local Serco Entrematic distributor is:

Corporate Head Office:

1612 Hutton Dr. Suite 140
Carrollton, TX. 75006
Tel. (972) 466-0707
Fax (972) 323-2661



The Bite That Locks On Tight

PITBULL®
SAFETY-LOC®